



The Handy Kenlin Group®



2024 BUYER'S GUIDE

- DRAWER, CABINET, CASE GOODS AND TABLE & CHAIR HARDWARE
- FURNITURE AND BEDDING INDUSTRIES

END-TO-END EXPERTISE

Maximize Your Product's Potential With a Single-Source Solution For All Innovation, Design, Manufacturing, Global Sourcing, and Seamless Delivery in Your Supply Chain.

Innovate

Innovation can take many forms, such as an improved design, a better approach to engineering, a more efficient production method, or an approach to sourcing and delivery that reduces costs and increases speed-to-market.

Produce

We redefine possibilities with Advanced Product Quality Planning (APQP). We can manufacture for you, manage the manufacturing process, or help you source the best partner.

Design

Transform concepts into reality with our visionary design team, crafting solutions that captivate the market and resonate with your customers. Our collaborative approach will produce a surge of new ideas, improved designs and enhanced engineering that may extend beyond modifying existing products for cost-efficient manufacturing.

Deliver

Our strategically located warehouses act as command centers, optimizing inventory management and minimizing lead times. We provide ease of scaling your operations without compromising on budget or efficiency.



At The Handy Kenlin Group, we don't just engineer and produce products; we craft success stories. Since 1898, we have partnered with organizations worldwide to provide end-to-end product expertise throughout the lifecycle of innovation, design, manufacturing, global sourcing, and delivery. As a people-first, values-based organization we lead with joy in what we do and where we do it, resulting in an exceptional service experience for our customers.

TABLE OF CONTENTS

Drawer Hardware

Back Bearings.....	6
Drawer Glides	7-9
Tack.....	7
Stud.....	7
Saw Slot Installation.....	7
Staple or Brad Installation.....	8
Tipper.....	8
Button Glides	9
Plastic Headed Tacks.....	9
Magnetic Hammer	
Metal Drawer Glides.....	
Drawer Divider Supports	
Utility Trays.....	10
Custom Trays.....	10
Tray Hangers.....	10
Drawer Outstops.....	11

Cabinet Hardware

Shelf Supports	12
The GRIPPER Locking Shelf Supports	12
Regular Shelf Supports	12
Soft Wood Supports	12
Plastic Shelf Supports w/Metal Pins	12
Shelf Pins	13
Spoon Type Metal Supports ...	13
Metal Pin-Type Supports	13
Fluted & Plain Shelf Pins.....	13
Retaining.....	13
Roller Catch	14
Glue/Staple Blocks	14
Fast Klip.....	14

Case Goods Hardware

Glass & Panel Retains.....	15
Tapered Pad Retainers.....	15
Standard & Disc Types.....	15
Mirror Clips.....	15
Floor Glides	16
Strip Glides	16
In-Plant Glides.....	16
RG Metal Base Cushion Glides w/screw	16
Cushion Glides w/screw.....	16
The Glide That Hides	17
The Heavy Duty Nylon Base Glides.....	17
Handy All-In-One Glide-T-Nut Assemblies	18
Heavy Duty Adjustable Leveling Glides	18
Metal Base Heavy Duty Leveling Glides	18
Adjustable Glides.....	18
Self-Leveling Glides.....	18
Leg Adjusters.....	18
Swivel Adjustable Levelers.....	19
Adjustable Levelers Support Bracket.....	19
Corner Brace	19
T-Nut.....	19
Door Wedges & Stops	20
Leg Protectors.....	20
Case Feet.....	20
Plastic Nail Bumpers	21
Hang Rod Flanges.....	21
Caster Sockets.....	21
Post Hole Liners	21

Table & Chair Hardware

Screw Plug Buttons	22
Nylon Hole Plugs.....	22
Tube Closures	22
Tube Caps.....	23
Table Wedges	23
Table Pins	23

Button Covering Equipment

Junior No. 1 Machine	24
No. 2 Machine	24
No. 5A Covering Machine.....	24
No. 5PA Covering Machine.....	25
No. 7PA Auto-Swivel Covering Machine	25
No. 9A Attaching Machine	25

Electric Button Covering Machines

No. 300 Machine	24
No. 300SH Machine.....	25
No. 400 Machine	25

continued

To place an order contact:
ReadytoWow@handykenlin.com

TABLE OF CONTENTS

Cutting Equipment, Tufting Machines

Cutters	26
No. 11 Cutting Machine	26
No. 40P Automatic Cutting Machine	26
No. 32P Automatic Cutting Machine	26
The Junior Tufter	26

Dies

Two-Piece Dies	27
Three-Piece Dies	27
Button Covering Process	27

Button Shells

Button Shells	28
Scale of Button Sizes	28

Button Backs & Twine

No. 9 Standard Wire Eye Backs ...	29
No. 44 Small Wire Eye Backs	29
Button Replacement Kit	29
Handy Tie Nylon	29
Twine, Nylon	29

Nail Button Backs, Washers & Prongs

No-Dent Corrugated Nail Backs ..	30
Threaded Nail Backs	30
No. 15 Spring Washers	30
Welded Serrated Studs & Retainers	30
Prongs	30

Prongs & Washers & Pivot Buttons

Finished Metal Buttons	31
Prong Button Tufting Tool	31
Prong Washers	31
Single & Joined Pivot	31

Loops & Tuftings

Nylon Hook Backs	32
Nylon Loops	32
Fastuft With Loop	32
No. 11 Tufting Disc	32
No. 28 Split Retainer Buttons	32
Finished Hook Button	32

Tufting Needles

Tufting Needles	33
Air Powered Ejector Needle	33
100 Regular	33
100 Ejector	33
Euro Tape Ejector Needle	33

Finished Buttons & Snaps

Assembled Snap Button	34
One Piece DuraSnap Backs	34
Square DuraSnap Backs	34
Designer Buttons	34
Durable Fasteners	34

Mattress Hardware

Handy Euro Mattress Tapes	35
Tufting Tapes	35
Rosettes	35
Felt Washers	35
Mattress Tufting Buttons	35
Ventilators, Handle Grommets, & Eyelets	35

Tack Strip

Velvet Edge Tack Strip	36
Flextrim	36

Nails & Rings

Decorative Nails	37
Nail Strip	37
Panel Nails	37
Snap Hooks & Rings	37
Round Rings, D-Rings	37

continued

To place an order contact:
ReadytoWow@handykenlin.com

Clips, Rings & Grommets

Clips.....	38
Hog Rings.....	38
Swatch Grommets	38
Brass Grommets	38
Floor Glides	38
Plastic Nail Glides	39
One- and Three-Prong Glides.....	39
Adjustable Glides.....	40
Non-Skid Glides	40
Support Bracket.....	40
Adjustable Levelers Swivel.....	40
Nylon Base w/black screw	41
Heavy Duty Nylon Base Glides.....	41
RG Metal Base Cushion Glides w/screw	41
Cushioned Glides w/screw.....	41
The Glide That Hides	42
Metal Base Heavy Duty Leveling Glides	42
T-Nuts.....	42
Glide T-Nut Assemblies.....	42
RG Metal Base Cushion Glides.....	43
Cushion Glides	43
Heavy Duty Insulated Glides.....	43
Double Nail Glides.....	43
The “Hold-in-Almost-Anything” Glide	43
Legs.....	44

Table & Cabinet Hardware

Tube Closures	45
Case Feet.....	45
Sockets.....	45

Drawer Guides

RITE-TRAK®.....	46
Glide Rite #180	48
Case Glides.....	48

To place an order contact:
ReadytoWow@handykenlin.com

BACK BEARINGS

Back Bearings

For an easy-opening, non-binding, low cost drawer installation, choose our Back Bearings. They're made from self-lubricating polyethylene for durability, and are available for either wood or metal center guides. Available in natural color, and special order in beige.

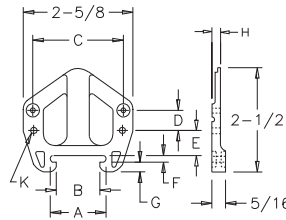

40-22

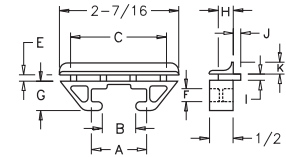

40-23

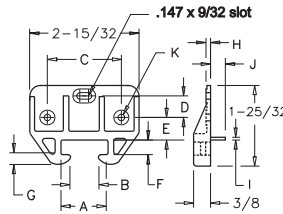
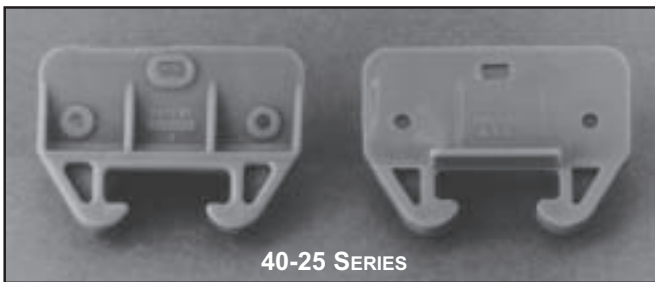

40-25 SERIES

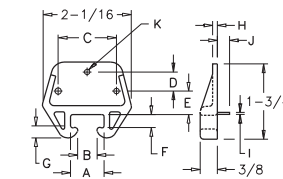
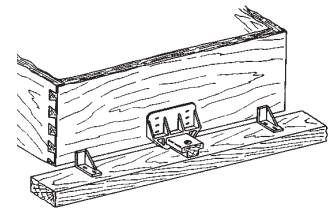

40-26 SERIES

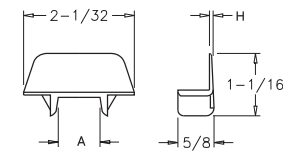
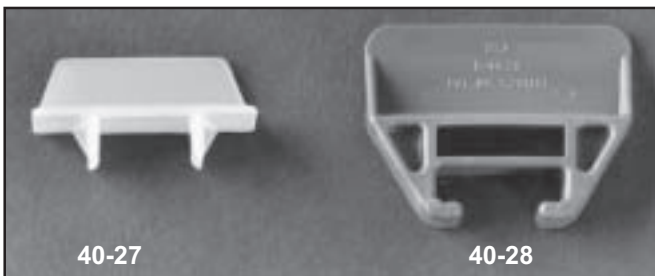
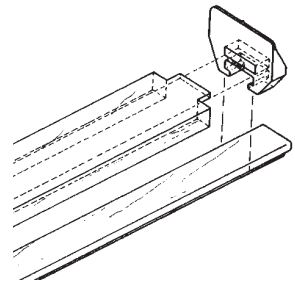

40-27

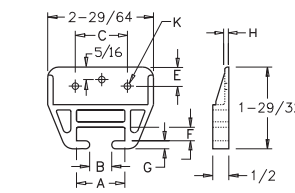

40-28

40-28H

PART	A(MIN.)	B(MIN.)	C	D	E	F(MIN.)	G	H	I	J	K	Pcs/box	WT(LBS)
40-22	1.281	1	2-1/8	1/2	5/8	1/8	1/4	3/16	N/A	N/A	9/64D (4)	2M	36
40-23	1.110	.640	1-59/64	N/A	.145	.270	5/8	5/16	1/8	5/32	1/4	2.5M	38
40-25	1.118	11/16	1-23/32	1/2	1/2	.286	1/4	1/8	N/A	N/A	.147D (2)	2.5M	46
40-25C	1.118	11/16	1-23/32	1/2	1/2	.286	1/4	1/8	1/16	3/8	.147D (2)	1.75M	34
40-25L	1.118	11/16	1-23/32	1/2	1/2	.286	1/4	1/8	1/16	3/8	.147D (2)	1.75M	34
40-25P	1.118	11/16	N/A	N/A	N/A	.286	1/4	1/8	N/A	N/A	N/A	2.5M	45
40-26	.775	.425	1-3/8	7/16	17/32	.280	1/4	.105	N/A	N/A	.147D (3)	3M	45
40-26L	.775	.425	1-3/8	7/16	17/32	.280	1/4	.105	1/16	3/8	.147D (3)	2M	32
40-26P	.775	.425	N/A	N/A	N/A	.280	1/4	.105	N/A	N/A	N/A	3M	46
40-27	13/16	N/A	N/A	N/A	N/A	N/A	N/A	1/16	N/A	N/A	N/A	4M	30
40-28	1.125	5/8	N/A	N/A	N/A	.275	3/16	3/32	N/A	N/A	N/A	1.6M	37
40-28H	1.125	5/8	1-1/4	N/A	7/16	.275	3/16	3/32	N/A	N/A	.156D (3)	1M	23

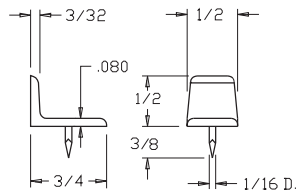
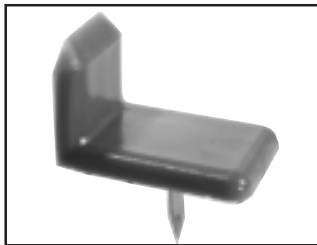

33-21

Tack

Our polyethylene Tack Type Corner Glide eliminates the need for staples or grooved front rails, and no additional machining is required. Simply drive the tack glide into place on the front rail and insert the drawer. Available in beige, 10M pcs per box-weight 20 lbs.

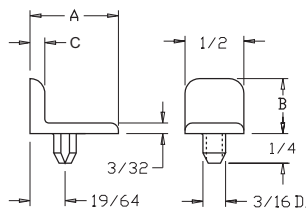

31-3

31-4

Stud

Stud Type Corner Glides offer strong vertical and horizontal gliding support for wood, metal, or plastic drawers. They're easily installed in 3/16" drilled or punched holes. Available in natural. Made of polyethylene.

PART	A	B	C	Pcs/Box	WT(LBS)
31-3	47/64	15/32	1/8	10M	19
31-4	47/64	13/32	15/64	10M	19

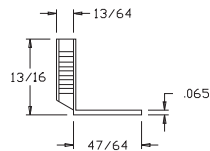

30-67

Saw Slot Installation

Our self-lubricating polyethylene Drawer Glides make any drawer easier to open--wood, metal or plastic. Use them with our Back Bearings for the ultimate in smooth drawer action. They mount in a simple 1/8" wide saw slot, supporting the drawer at the front rail while guiding it along the sides.

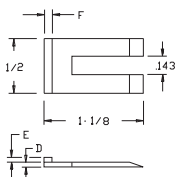

50-101

50-102

Shims are available for simple, economical drawer front alignment with any series 30 glide. Available in natural.

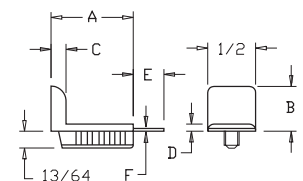
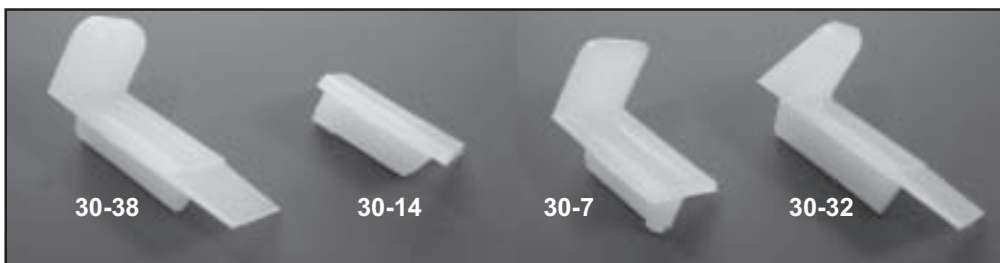

30-7	30-8
30-32	30-38
30-39	30-14

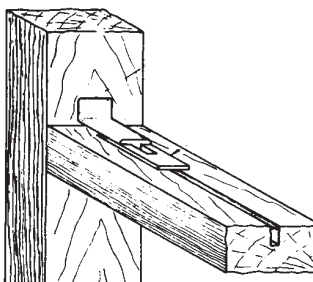

PART	A	B	C	D	E	F	Pcs/Box	WT(LBS)
30-7	3/4	7/16	.075	.070	N/A	N/A	10M	17
30-8	3/4	7/16	1/8	.070	N/A	N/A	10M	21
30-32	55/64	15/32	15/64	.065	3/8	1/32	10M	25
30-38	55/64	7/16	5/32	.075	3/8	3/64	10M	26
30-39	.825	7/16	.075	.075	3/8	3/64	10M	22
30-14	3/4	N/A	N/A	.070	N/A	N/A	10M	15
30-67	SEE DRAWING						10M	15
50-101	SEE DRAWING (SHIM)			1/32	1/32	1/16	10M	6
50-102	SEE DRAWING (SHIM)			1/16	N/A	N/A	10M	10

DRAWER GLIDES

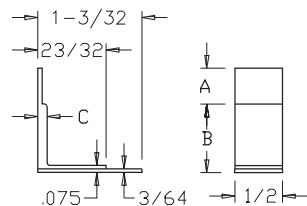

32-35 **32-36**
32-384 **32-37**

Staple or Brad Installation

These self-lubricating polyethylene glides can be easily installed with staples or brads. The thinner tab allows the wire staple or brad head to be positioned below the bearing surface of the glide. No holes are needed for accurate placement. Available in natural color.

PART	A	B	C	Pcs/Box	Wt(LBS)
32-35	3/8	23/32	.075	10M	22
32-384	7/16	19/32	13/64	5M	20
32-36	N/A	1/2	5/64	10M	17
32-37	N/A	N/A	N/A	10M	12

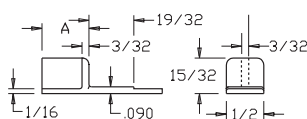
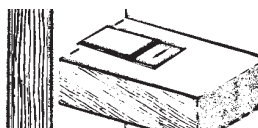

32-148 **32-158**

PART	A	Pcs/Box	Wt(LBS)
32-148	17/32	5M	15
32-158	5/8	10M	15

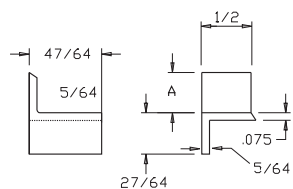

32-33 (R) **32-128**
32-34 (L)

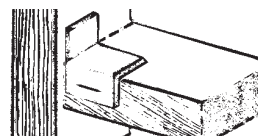

PART	A	Pcs/Box	Wt(LBS)
32-33 (R)	.409	10M	21
32-34 (L)	.409	10M	21
32-128	N/A	15M	15

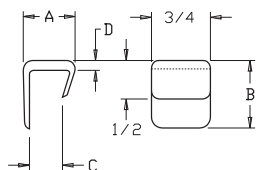

23-2 **23-6**
23-40

Tipper

If your furniture has a narrow side or tipper rail, use these Tipper Glides. Made from long lasting polyethylene, they can be attached with a single staple. Depending on the location of the frame members, they may be installed alone on drawer backs or in pairs mounted on drawer sides.

PART	A	B	C	D	COLOR	Pcs/Box	Wt(LBS)
23-2	21/32	27/32	3/8	1/8	Nat	10M	30
23-6	21/32	29/32	3/8	3/16	Nat	10M	41
23-40	17/32	3/4	1/4	1/16	Nat	10M	22
23-347	SEE DRAWING				Wal	7M	33

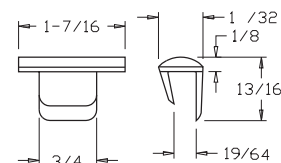

23-347

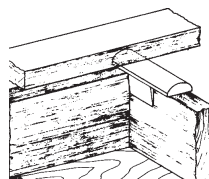

DRAWER GLIDES & DIVIDERS

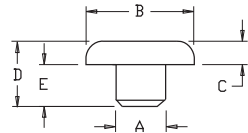

31-Stud Series Glides

PART	A	B	C	D	E	COLOR	Pcs/Box	WT(LBS)
31-150	.189	3/8	1/8	7/16	5/16	Nat	10M	7
31-151	.189	3/8	11/64	31/64	5/16	Nat	10M	9
31-156	.189	3/8	19/64	39/64	5/16	Nat, Wal	10M	12
31-4036	5/16	9/16	1/8	11/32	7/32	Nat, Bge	10M	16
31-153	1/4	9/16	1/8	11/32	7/32	Nat	8M	15

Bge—Beige Nat—Natural Wal—Walnut

Button Glides

Use our resilient, versatile polyethylene glides wherever sliding or bumping members may create noise, wear or friction. Button Glides install easily in a round drilled or punched hole in wood, sheet metal or plastic—just about anything.

Plastic Headed Drawer Glides

Made of polyethylene

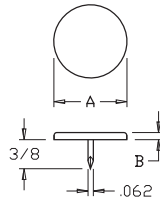

Round Tacks

ROUND TACKS

PART	A	B	COLOR	Pcs/Box	WT(LBS)
33-17	1/2	.080	Bge	10M	10
33-579	3/4	1/8	Bge, Wal, BIK	10M	20
33-580	3/4	3/16	Wal	5M	15
33-600	3/4	3/32	Wal	10M	17
33-601	1-1/8	3/32	Bge	5M	20

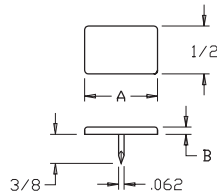

Rectangular Tacks

RECTANGULAR TACKS

PART	A	B	COLOR	Pcs/Box	WT(LBS)
33-16	3/4	.080	Bge	10M	15
33-68	3/4	.120	Bge	10M	18
33-2101	1-1/4	.080	Bge	5M	12
33-5320	1-1/4	1/8	Wal	10M	35

Magnetic Hammer (Not shown)

To speed and simplify installation of Plastic Headed Tacks and other tack-type parts, use our Magnetic Hammer. The 2" wide head makes it easier to work in tight spaces. Part no. 33-752.

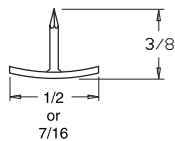

Metal Drawer Glide

Metal Drawer Glides

Economical and easy to use. Available in 1/2" dia. head (part # 242-0140) and 7/16" dia. head (part # 242-0150), with brite zinc finish.

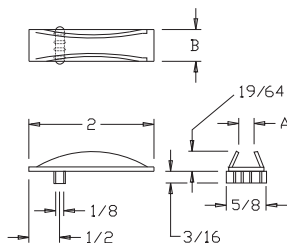

Tack, Plain & Saw Slot

Drawer Divider Supports

Beige polyethylene

TACK DIVIDER SUPPORTS

PART	A	B	Pcs/Box	WT(LBS)
83-189	1/4-5/16	9/16	2M	12

PLAIN DIVIDER SUPPORTS

83-788	1/8-3/16	15/32	5M	15
83-789	1/4-5/16	9/16	5M	18

SAW SLOT DIVIDER SUPPORTS

83-190	1/4-5/16	9/16	5M	20
83-191	1/8-3/16	15/32	5M	17

UTILITY TRAYS



Utility Trays

Our Utility Trays complement all styles of furniture. The colors are molded throughout the satin-finished polystyrene trays to make them scratch resistant. Rounded compartment corners make them easy to clean with a damp cloth. Available in beige and black.

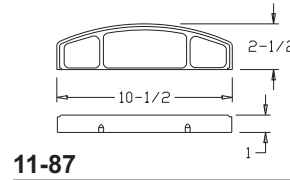

11-87

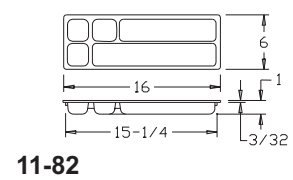

11-82

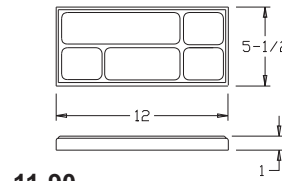

11-90

PART	Pcs/Box	WT(LBS)
11-82	100	50
11-87	112	22
11-90	50	22



Custom Trays

Custom trays are available in specified lengths ranging from 9-1/2" to 16-11/16" in increments of 1/16". 1000 minimum order on custom trays. Available in beige and black. Made of polystyrene.

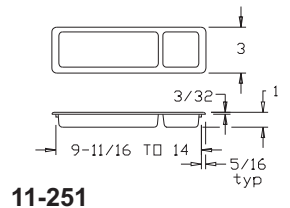

11-251

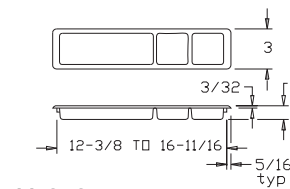

11-252

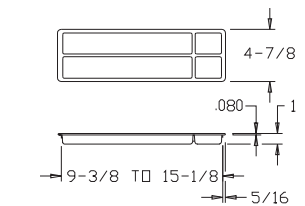

11-253

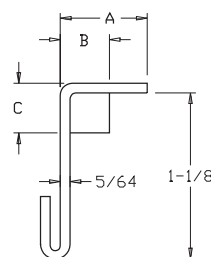

Tray Hangers

Tray Hangers

Tray Hangers provide the ideal method for installing the 11-90 Pencil Trays. The bottom edge of the tray fits over the hanger clip. A drop of adhesive placed in the hanger before assembly makes the installation permanent. Tray Hangers are available in colors to match the trays. Made of polystyrene.

PART	A	B	C	PKG	WT(LBS)
11-194	19/64	N/A	N/A	200	5
11-195	7/16	3/16	1/4	200	5
11-197	1/2	1/4	1/4	200	5
11-4035	7/16	N/A	N/A	200	5

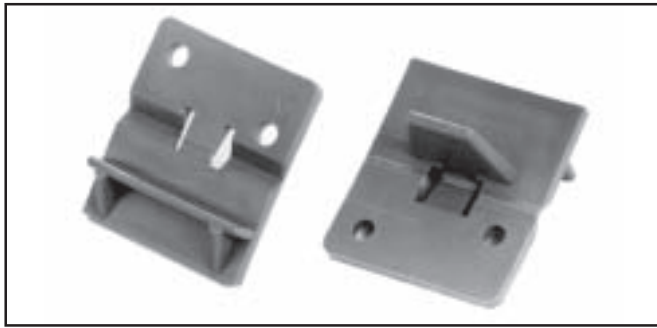

DRAWER OUTSTOPS

Handy offers two types of Drawer Outstops--removable and non-removable. The removable Drawer Outstop mounts on the back of a drawer to prevent it from being pulled out accidentally. Made of polypropylene.

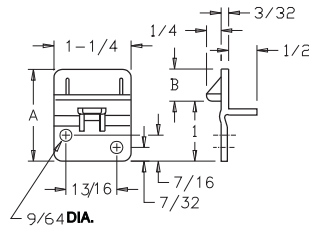

51-Series Removable

SCREW TYPE (USE WITH #6 OVAL HEAD WOOD SCREW)					
PART	A	B	COLOR	Pcs/BOX	WT(LBS)
51-423	1-3/4	3/4	Beige	3M	25
51-424	2	1	Beige	2.5M	23
51-468	1-3/8	3/8	Beige	2.5M	17
STAPLE TYPE (NO HOLES)					
51-426	1-3/4	3/4	Beige	3M	25

REMOVAL OF DRAWER		REINSERTION OF DRAWER	
Outstop prevents removal of drawer.	Tip forward to remove.	When drawer is inserted, Outstop tips forward.	Automatically snaps upright.

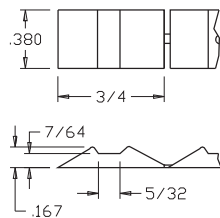

51-421 Non-Removable

Center Rail Drawer Outstops (non-removable)

Drawer Outstops for center rail applications are used with specified wood and metal drawer slides. Available in strips of eight for easy staple-on application. Made of polyethylene.

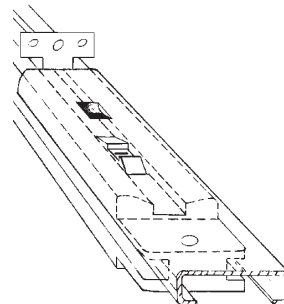

SHELF SUPPORTS

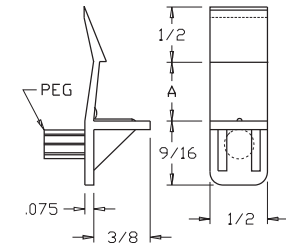

The Gripper

The Gripper Locking Shelf Support

This patented shelf support locks shelves in place, installs easily in cabinets, vanities and wall units. The shelf slides down into the support quickly; compression grips the shelf firmly. Made of polypropylene.

FIT SHELF A	PEG DIA.	PEG LGTH.	COLOR	Pcs/Box	Wt(LBS)
1/2	1/4	7/32	Wht, Wal Nat, Blk Bge, Brn	5M	17
	5/8	3/8			
3/4	5mm	6mm			
	5mm	8mm			

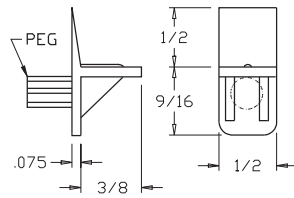

Regular Supports

Regular Shelf Supports

These tough polypropylene supports have two braces under their shelf platform for added strength and durability. The tapered top edge guides the shelf into position. 5M pcs per box-weight 11 lbs.

PEG DIA.	PEG LGTH.	COLOR
1/4	7/32	Wht
	9/32	Wal
	3/8	Bge
5mm	6mm	Brn
	8mm	Nat

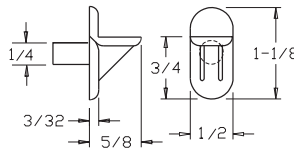

25-Series

Soft Wood Supports

Rounded edges reduce risk of support digging into soft wood surfaces while providing strength and durability. Made of polystyrene.

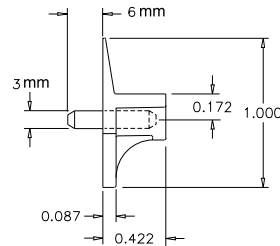

243-5070

Plastic Shelf Supports w/Metal Pins

Handy's new clear plastic shelf support with steel pins provide a high level of strength while blending in with any cabinet finish.

PART	PEG DIA.	PEG LGTH	A	Pcs/Box	WT(LBS)
243-5070-005	3MM	6MM	.172	5M	
243-5040-004	5MM	8MM	.156	4M	
243-5030-00C25	1/4	3/8	.180	2.5M	

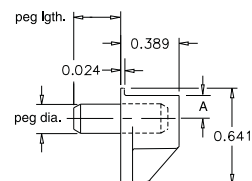

243-5040 243-5030

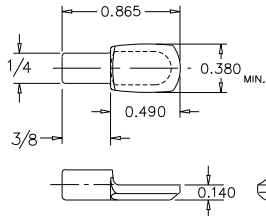

1/4 x 3/8 Peg

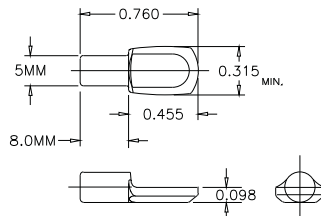

5mm x 8mm Peg

Spoon Type Metal Supports

Handy's metal shelf supports are available in standard and long support surfaces. Inquire about special finishes. Reinforce shelf pin holes with Handy's metal sleeve eyelet.

PART	PEG	FINISH	Pcs/BOX	WT(LBS)
243-8030-21C25	1/4" x 3/8"	gilt	2.5M	27.5
243-8030-28C25	1/4" x 3/8"	nickel	2.5M	27.5
243-8030-85C25	1/4" x 3/8"	black	2.5M	27.5
243-8030-86C25	1/4" x 3/8"	ant brs	2.5M	27.5
243-8040-214	5mm x 8mm	gilt	4M	23.5
243-8040-284	5mm x 8mm	nickel	4M	23.5
243-8040-854	5mm x 8mm	black	4M	23.5
243-8040-864	5mm x 8mm	ant brs	4M	23.5



Metal Pin-Type Supports

Simple, economical and durable, with brite nickel finish. Available in size 5mm x 24mm (part # 243-6050) and 3/16" x 1" (part # 243-6060).

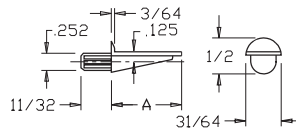

25-171

25-471

Fluted & Plain Shelf Pins

Handy's Fluted Shelf Pins were designed to adjust to fit 1/4" holes which may be slightly over- or under-sized. Flexible flutes also resist turning. Our pins will not scratch glass or wood finishes and are not affected by waxes or cleaning materials. Available in Lexan or Celcon.

PART	A	COLOR	Pcs/Box	WT(LBS)
25-171	1/2	Clr, Wal	5M	10
25-471	1	Wal	10M	32
Plain Shelf Pin				
25-170	15/32	Wal	5M	11

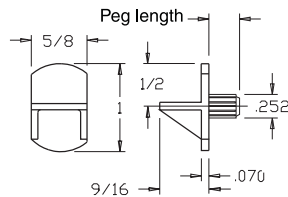

25-469

25-459

Retaining Shelf Supports

Capture the shelf from the front and prevent it from sliding forward. Part 25-469 is used in left and right front corners. Part 25-470 matches height and is used as back support. Available in Lexan or Celcon.

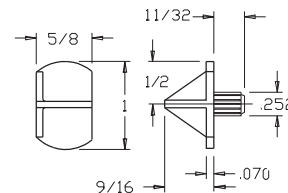

25-470

PART	PEG LENGTH	COLOR	Pcs/Box	WT(LBS)
25-469	11/32	Clr, Wal	10M	42
25-459	15/32	Clr, Wal	10M	42
25-470	11/32	Clr, Wal	10M	42

Wal-Walnut Clr-Clear

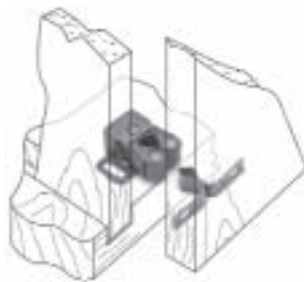

ROLLER CATCH

Handy catches are solid steel, bronze plated or custom finished. Designed for precise installation, the slotted strike plates are easy to position and adjust. Spring-activated rollers are polyethylene, so wood finishes won't discolor or damage them. Doors open easily, close smoothly, and are held positively—for years and years. Available in sets and separate components.

PART	TYPE	Pcs/Box	WT(LBS)
24-1200-865	low base	500	20
24-1300-865	high base	500	23

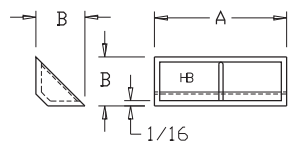
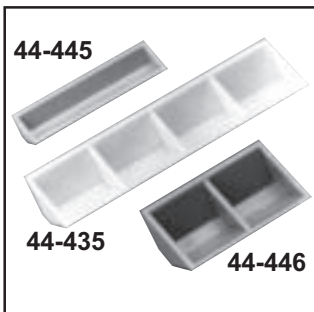

Glue / Staple Blocks

GLUE / STAPLE BLOCKS

Handy's Glue Blocks may be glued and/or stapled to wood. High impact styrene resists shattering when stapled.

GLUE / STAPLE BLOCK					
PART	A	B	COLOR	Pcs/Box	WT(LBS)
44-445	2-1/4	7/16	Bge	5M	19
44-435	4	3/4	Bge, Wht	1M	15
44-446	2	7/8	Bge, Wht	2M	18
STAPLE BLOCK					
44-461	2	3/4	Nat	2M	12
44-447	2-3/4	23/32	Wht, Wal	2M	18

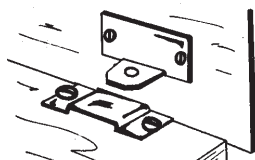

FAST KLIPS

Handy Fast Klip Assembly Sets eliminate most time-consuming joining and skilled labor. Align and fasten the clips on panels, snap them into place. Perfect for RTA or factory assembled units. Brass plated. 1000 sets to 40 lb. carton. Inquire for special finishes. Part # (female clip) 243-0900 (male clip) 243-0910

GLASS & PANEL RETAINERS

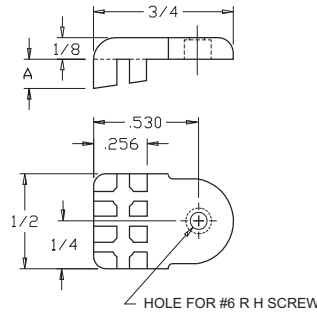

Tapered Pad Retainers

Tapered Pad Retainers

Our U.S. patented # 4,680,915 one piece Tapered Pad Panel Retainer combines high strength with flexibility. As the retainer is screwed to a frame, the tapered "cat's paw" pad presses against the glass or plastic panel, serving as a cushion to prevent breakage. It holds the panel with a firm, gentle grip. The retainers are ideal for securing curved glass, and their low profile keeps them inconspicuous. Available with screws attached. Standard color is brown. Made of polyethylene.

PART	PANEL THICKNESS	A	Pcs/BOX	WT(LBS)
21-286	FLUSH TO 1/32 RECESS	.060	10M	15
21-290	1/16 TO 3/32 RECESS	.125	10M	17
21-291	1/8 TO 5/32 RECESS	.187	10M	18
21-292	3/16 TO 7/32 RECESS	.250	10M	20

Made of Lexan or Celcon.

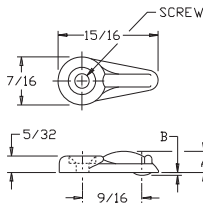
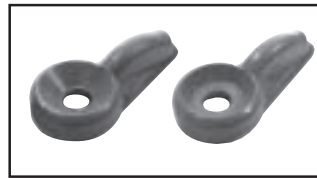
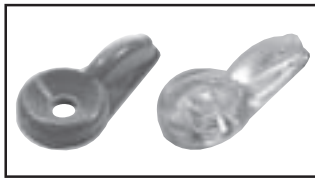

21-10 **21-179**
21-180 **21-183**

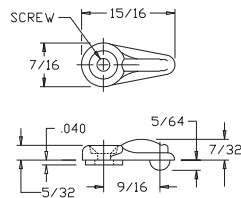

21-184 **21-185**

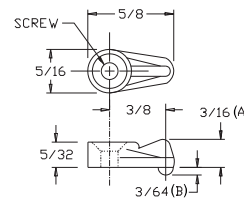

21-182

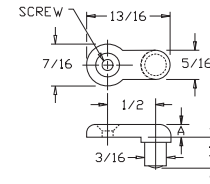

21-281 **21-313**

PART	A	B	SCREW	CTR SINK	COLOR	Pcs/BOX	WT(LBS)
21-10	7/32	1/32	.125 DIA, #5F.H. SCREW	YES	BGE	10M	15
21-179	7/32	1/32	.125 DIA, #5R.H. SCREW		BGE	10M	17
21-180	7/32	1/8	.143 DIA, #6R.H. SCREW		BGE, CLR	10M	17
21-183	7/32	1/32	.143 DIA, #6R.H. SCREW		BGE	10M	15
21-184	SEE DRAWING		.143 DIA, #6R.H. SCREW		BGE	10M	15
21-185	SEE DRAWING		.143 DIA, #6F.H. SCREW	YES	BGE	10M	19
21-182	3/16	3/64	.125 DIA, #5F.H. SCREW	YES	BGE	10M	8
21-281	1/8	5/16	.125 DIA, #5F.H. SCREW	YES	WAL, CLR	5M	11
21-313	1/8	1/8	.125 DIA, #5F.H. SCREW	YES	BGE, CLR	5M	8

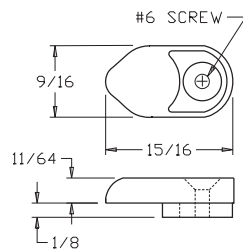
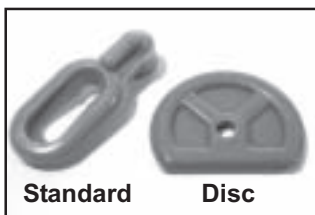

45-433

Mirror Clips

Our surface mounting clips are made to secure glass or panels 1/8" thick. They're available in clear, 10M pcs per box-weight 30 lbs. Made of Crystal Styrene material.

FLOOR GLIDES



Strip Glides

Our Strip Glides are molded in strips of eight. To install, position the first glide on a leg of the furniture, using the remainder of the strip as a handle. Drive a staple through the center of the glide, then twist and lift the strip to snap it away from the installed glide. Use for bumpers to prevent finish damage. Made of polyethylene. Extra tough strip glides are also available. Ask for samples of part No. 32-500.

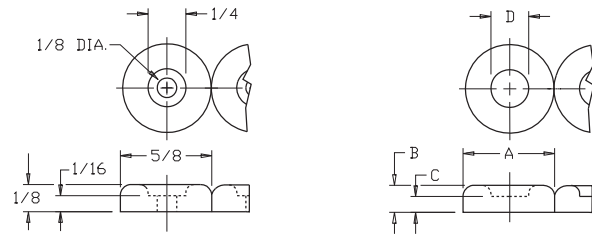

32-116

32- SERIES

PART	A	B	C	D	COLOR	Pcs/Box	WT(LBS)
32-116	(SEE DRAWING FOR USE WITH RIVETS)				Bge, Nat	10M	10
32-117	5/8	3/16	3/32	1/4	Bge, Nat	10M	15
32-127		1/8	1/16	1/4	Bge, Nat	10M	10
32-129	1/2	1/8	1/16	1/4	Nat	10M	7
32-449	3/4	3/16	3/32	1/4	Wal, Nat	10M	24
32-452		3/16	3/32	5/16	Wal, Nat	10M	24
32-453		1/4	3/32	5/16	Wal, Nat	10M	28

Bge-Beige Nat-Natural Wal-Walnut

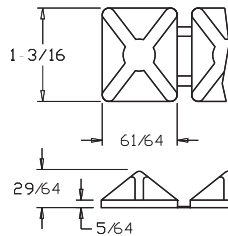

32-839

In-Plant Glides

Stapled to the bottom frame rail to slide the furniture around the plant during assembly and protect the lower edges of upholstery. They're supplied in strips of four. Available in natural, 4M pcs per box-weight 24 lbs. Made of polyethylene.

RG Metal Base Cushion Glides w/screw

Our special design keeps the screw from turning in the polypropylene cushion.

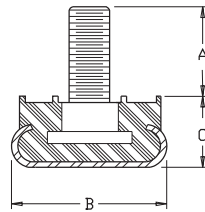

RG 100 SERIES

SCREW WITH 1/4-20 THREAD						
PART	A	B	C	Pcs/Box	WT(LBS)	
RG 105	1/2	7/8	13/32	1M	27	
	3/4	7/8	13/32	1M	32	
	1-1/8	7/8	13/32	1M	35	
RG 110	1/2	1-1/16	13/32	1M	36	
	1-1/8	1-1/16	13/32	1M	43	
SCREW WITH 5/16-18 THREAD						
RG 105	1	7/8	13/32	1M	35	

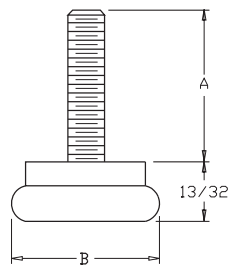

33-8000 SERIES

Cushion Glides w/screw

Non-rusting and economical. Made of polyethylene. For added durability inquire about nylon plastic base.

SCREWS WITH 1/4-20 THREAD				
PART	A	B	Pcs/Box	WT(LBS)
33-8010	1/2	1	1M	19
33-8030	3/4	1	1M	22
33-8060	1	1	1M	25

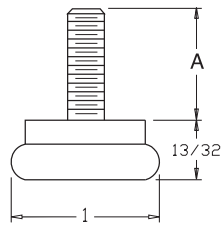

33-8010 33-8030

The Glide That Hides

If you want your furniture to look like it's floating above the floor, Handy's new clear plastic glides do the trick. Available with 1/4-20 x 1/2" and 3/4" screws.

PART	A	Pcs/Box	WT(LBS)
33-8010	1/2	1M	20
33-8030	3/4	1M	23

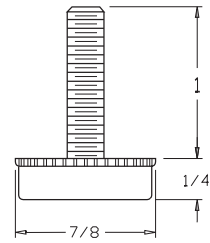

33-5340

The Heavy Duty Nylon Base Glide

This nylon base, with its 5/16-18 x 1" screw, supports the heaviest pieces. The 7/8" base lets you set shelving units flush together. Available in black, 1M pcs per box-weight 30 lbs.

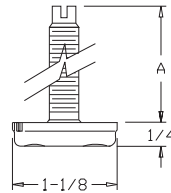

Adjustable Levelers

Adjustable Levelers

Level wall units, partitions, cabinets, appliances, and furniture easily and quickly. The 5/16-18 zinc plated bolt screws into T-Nuts, etc. and can be adjusted from inside or outside the cabinet. Made of polyethylene.

PART	THREAD	A	COLOR	Pcs/Box	
33-6970	5/16-18	2-1/4	Beige	250	15
33-6980	5/16-18	2-3/4	Beige	250	18
33-6990	5/16-18	3-1/4	Beige	250	20
33-7000	5/16-18	3-3/4	Beige	250	23

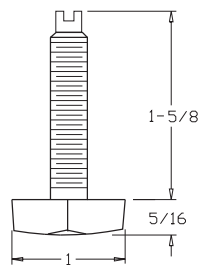

33-6600S

Heavy Duty Adjustable Leveling Glides

This is one of the strongest glides available for heavy furniture. Base is super-tough black nylon. The 5/16-18 x 1-5/8" zinc plated steel bolt has a specially designed head that anchors it permanently in the base. Hexagonal base is easy to adjust with a wrench or screwdriver. Available in black, 500 pcs per box-weight 23 lbs.

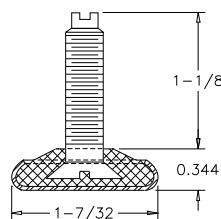

33-5500

Metal Base Heavy Duty Leveling Glides

Strong black oxide steel base with 5/16-18 x 1-1/8" slotted bolt. Strong enough to handle the heaviest loads. 500 pcs per box-weight 23 lbs.

FLOOR GLIDES

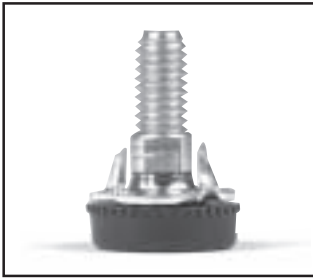

Handy All-In-One Glide-T-Nut Assemblies

Cut Costs, Save Installation Time

The threaded insert is already screwed onto the glide. All-In-One assemblies are economical as well. And they are available with any of Handy's big line of floor glide--basic screw glides, cushioned glides, heavy duty insulated glides, adjustable glides, heavy duty leveling glides and self-leveling glides. Also available with propeller T-Nut.

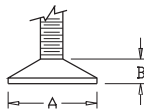

Type A Glides

Adjustable Glides

Made of polyethylene.

TYPE A GLIDES						
PART	A	B	THREAD	COLOR	Pcs/Box	Wt(LBS)
33-122	1-1/2	19/64	5/16-18x1-1/2 LG.	Blk, Nat	500	24
33-123	1-1/2	19/64	1/4-20x1 LG.	Bge, Nat, Blk	500	14
33-355	1-1/2	19/64	1/4-20x1-1/2 LG.	Nat, Blk	500	16
33-357	1-1/2	19/64	1/4-20x5/8 LG.	Nat, Blk	500	31
•• 33-516	1-1/2	19/64	3/8-16x1-1/2 LG.	NAT, BLK	500	31
33-6010	2	25/64	3/8-16x1 LG.	Bge, Blk	400	24
•• 33-6011	1-3/4	21/64	3/8-16x1-1/2 LG.	Bge, Nat, Blk	400	27

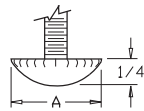

Type B Oval Base Glides

TYPE B OVAL BASE GLIDES					
PART	A	THREAD	COLOR	Pcs/Box	Wt(LBS)
33-124	5/8	1/4-20x1 LG.	Bge, Nat	1M	15
• 33-131	7/8	1/4-20x1 LG.	Bge, Nat	1M	18
33-132	1	1/4-20x1 LG.	Bge, Nat, Blk	1M	20
33-133	1-1/8	1/4-20x1 LG.	Bge, Nat	1M	22
33-139	1-1/8	1/4-20x5/8 LG.	Bge, Nat	1M	18
33-345	1-1/8	1/4-20x1/2 LG.	Bge, Nat	1M	11
33-356	5/8	1/4-20x5/8 LG.	Bge, Nat, Blk	1M	11
33-359	5/8	1/4-20x7/16 LG.	Blk	1M	11
33-364	1-1/8	1/4-20x1-1/2 LG.	Bge, Nat	1M	13
•• 33-6027	1-1/8	1/4-20x1-1/2 LG.	BGE	1M	25

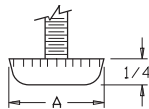

Type B Flat Base Glides

TYPE B FLAT BASE GLIDES					
• 33-130	3/4	1/4-20x1 LG.	Bge, Nat, Blk	1M	18
33-232	1	1/4-20x1 LG.	Blk	1M	21
33-235	1-1/8	1/4-20x1/2 LG.	Blk	1M	20
• 33-5322	1	5/16-18x1-5/8 LG.	Nat	500	27

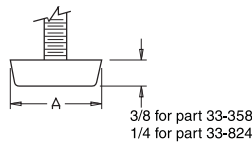

Type C Glides

TYPE C GLIDES					
33-358	1-1/8	5/16-18x1-1/2 LG.	BGE, NAT, BLK	500	24
33-824	1/2	#6-32x3/4 LG	NAT	5M	23

• Glide available with T-Nut only

•• Screw slot

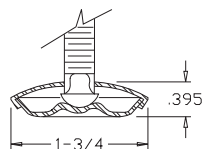

LA 175

Leg Adjusters

These Heavy Duty Leg Adjusters are ideal for use on heavy desks, game tables, vending and pinball machines or jukeboxes. The bright zinc plated glides may be used with T-Nuts or threaded bases. They are assembled with 3/8-16 bolts. Please inquire for other sizes and finishes.

BOLT LGTH	THREAD	Pcs/Box	Wt(LBS)
1-1/2	3/8-16	500	45
2	3/8-16	300	31
2-1/2	3/8-16	200	22
3	3/8-16	200	24

FLOOR GLIDES & T-NUTS

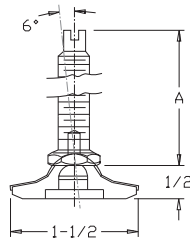

Swivel Adjustable Levelers

Swivel Adjustable Levelers

These levelers give you extra flexibility with a bolt that swivels in the base to 6° from vertical. The nickel plated 3/8-16 bolt is slotted at the top and has a hex shoulder at the bottom for adjustment from inside or outside the cabinet. Made of polyethylene.

PART	THREAD	A	Pcs/Box	Wt(LBS)
33-7500	3/8-16	1-1/2	250	16
33-7510	3/8-16	2-1/2	250	22
33-7520	3/8-16	3	250	25
33-7530	3/8-16	3-1/2	250	27
33-7540	3/8-16	4	250	29

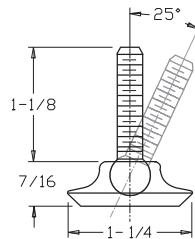

33-134

Self-Leveling Glides

Tough polyethylene base molded around threaded zinc plated shank distributes loads and keeps metal from touching floor or carpet.

Durable swivel joint adjusts glide automatically to angles up to 25° from vertical. Installs in 1/4-20 T-Nut. Available in black, natural and beige, 500 pcs per box-weight 16 lbs.

Support Bracket

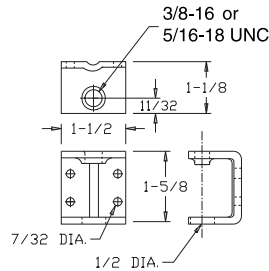
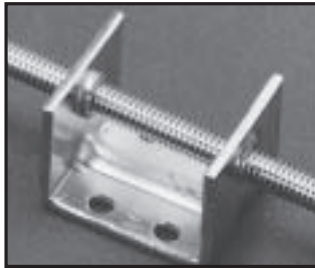

SB-8038-15

Corner Brace

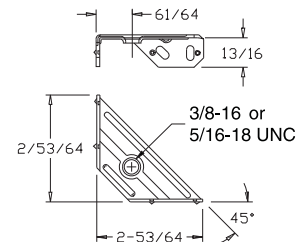

CB-9038-15

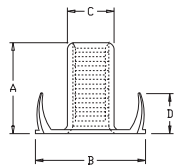

T-Nuts

T-NUTS

Multi-prong and propeller T-Nuts have slightly beveled and tapered barrels for easy insertion. Plain steel or zinc plated.

PART	THREAD	A	TYPE	B	C	D	Pcs/Box	Wt(LBS)
58129	10-24	9/32	3 PRONG	3/4	.230	1/4	5M	30
59038		9/32	6 PRONG	3/4	.230	1/4	5M	30
756		13/32	6 PRONG	3/4	.230	1/4	5M	36
59045	10-32	9/32	6 PRONG	3/4	.230	1/4	5M	30
59013		5/16	3PRONG	3/4	.305	1/4	5M	39
59015	1/4-20	5/16	6PRONG	3/4	.303	1/4	5M	39
58696		7/16	3 PRONG	3/4	.306	3/8	5M	45
936		7/16	6 PRONG	3/4	.306	1/4	5M	46
58686		9/16	3 PRONG	3/4	.306	3/8	3M	31
59028		7/16	PROPELLER	3/4	.306	N/A	2M	46
58703		3/8	4 PRONG	7/8	.385	1/4	2.5M	34
59044	5/16-18	3/8	6 PRONG	7/8	.385	9/32	2.5M	34
58753		5/8	3 PRONG	7/8	.389	7/16	2M	36
58708		5/8	4 PRONG	7/8	.389	9/32	2M	36
59053	3/8-16	7/16	6 PRONG	1	.453	3/8	1.3M	26

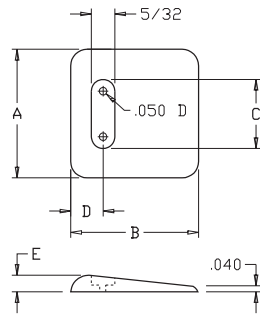

DOOR WEDGES & STOPS

Handy Door Wedges assure proper positioning of hinged doors when closed, even though the case or cabinet may be distorted from standing on an uneven floor. The self lubricating wedges guide the doors into their proper position, preventing damage to the finish. Install them at the top or the bottom of double doors, or along the sides of single doors. Made of polyethylene.

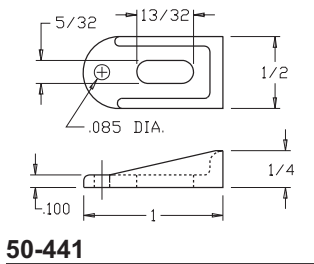

50-Series

PART	A	B	C	D	E	COLOR	Pcs/Box	WT(LBS)
50-111	3/4	3/4	3/8	1/4	.075	Bge, Wal	8M	9
50-443	1	1	3/8	1/4	1/8	Bge, Wal, Nat	10M	29
50-454	23/32	23/32	31/64	7/32	11/64	Wal	10M	17
50-457	31/32	3/4	9/16	1/4	.080	Bge, Wal	5M	8
50-441	SEE DRAWING-MADE OF POLYPROPYLENE					Wal, Blk	5M	10

50-441

LEG PROTECTORS

Handy Leg Protectors are especially suited for laboratory and institutional furniture. They are made from a chemically inert, low-density polyethylene which is not readily attacked by acids or other substances normally found in labs. The Protectors have an open bottom which permits them to slide down over bolts or leveling devices, flush with the floor. Available in black.

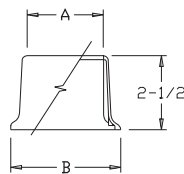

Leg Protectors

PART	A	B	Pcs/Box	WT(LBS)
71-510	2	3-1/8	250	19
71-511	2-1/4	3-3/8	200	18
71-512	2-1/2	3-5/8	200	20

CASE FEET

Our molded Case Feet are available in a variety of sizes for a wide range of applications. They can easily be attached to wood, metal or plastic with screws and other fasteners. Their multi-ribbed design offers exceptional strength to take heavy loads without deforming. They may also be used as floor glides and bumpers for hinged or sliding doors. Available in brown or black. Made of polyethylene.

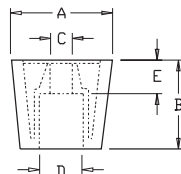

29-Series

PART	A	B	C	D	E	Pcs/Box	WT(LBS)
29-140	7/8	1/2	13/64	3/8	1/4	10M	49
29-141	7/8	5/8	13/64	3/8	1/4	8.5M	41
29-142	1	3/4	13/64	3/8	3/8	5M	44
29-143	1-1/8	7/8	1/4	15/32	3/8	3.5M	35
29-144	1-1/8	1	1/4	1/2	3/8	3.25M	49
29-145	7/8	1/2	1/4	3/8	1/4	10M	48
29-275	7/8	3/8	5/32	5/16	3/16	10M	41

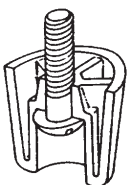

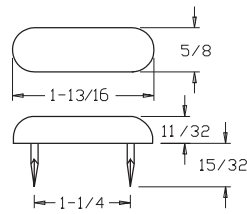

34-105

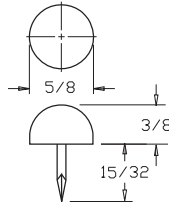

34-106

PLASTIC NAIL BUMPERS

You'll find a use for the single or double nail Plastic Nail Bumpers where you want to protect a finish, keep a fragile part from breaking, or eliminate noise. Put them on the covers of hampers, tool chests, cedar chests or toy boxes. The Two-Nail Bumpers are often used on toilet seats, and the Single-Nail Bumpers are suitable for use on toilet seat covers. They will not stain, corrode, or discolor with age. Strong soaps, detergents, or disinfectants won't harm them. Made of polyethylene.

PART	COLOR	Pcs/Box	WT(LBS)
34-105	Brn, Wht	2M	23
34-106	Brn, Wht	5M	16

Brn—Brown Wht—White

HANG ROD FLANGES

Our plastic Hang Rod Flanges provide an inexpensive method of installing wood or metal hang rods of all types. They're not only excellent for supporting clothes closet and shower curtain rods, but also can serve as vertical spindles in banisters, railings and room dividers. They're designed for a snug fit on 1" to 1-1/4" rods and are easily installed with three screws or nails. Made of polyethylene.

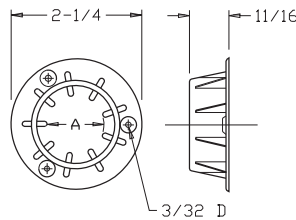

Hang Rod Flanges

PART	A	COLOR	Pcs/Box	WT(LBS)
44-55	1-1/4	Beige	1M	20
44-58	1	Beige	1.3M	20

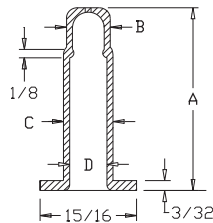
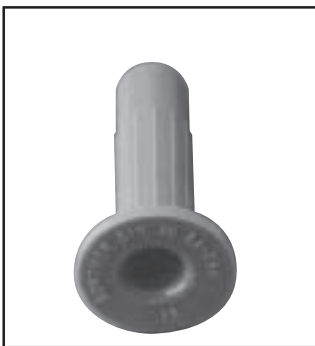

Caster Sockets

CASTER SOCKETS

These self-lubricating Plastic Caster Sockets are a major improvement over metal types. They absorb caster noise and won't squeak. They work equally well with ball-bearing stem or plain-stem casters. Sockets are vented to prevent collapse when driven into blind holes. Their ridged stems hold them securely in place. Available in beige. Made of polyethylene.

PART	A	B	C	D (CASTER STEM)	HOLE SIZE REQ'D	Pcs/Box	WT(LBS)
51-248	1-11/16	.430	.460	5/16 Dia.	7/16 Dia. x 1-7/8 Deep	5M	30
51-259	1-47/64	.488	.515	3/8 Dia.	1/2 Dia. x 1-7/8 Deep	4M	28

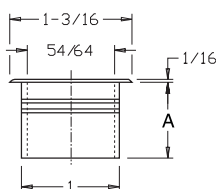

Post Hole Liners

POST HOLE LINERS

These Post Hole Liners are also suitable for use as communion cup holders and wire management. Attractive and tough, they provide protection for fine wood furniture. They are pliable, and made of low density polyethylene. For easy installation and a tight fit.

PART	A	COLOR	Pcs/Box	WT(LBS)
28-455	3/8	gold	8M	20
28-458	11/16	gold	4.5M	20

TABLE & CHAIR HARDWARE

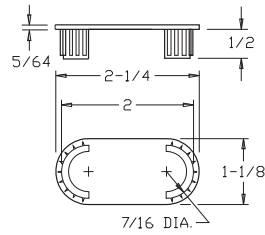

38-509

SCREW PLUG BUTTONS

Our Screw Plug Buttons are the economical, attractive alternative to wooden buttons. They install quickly and easily, with ridges molded around the sides to hold them securely. Try them on chairs or shelf units. They're particularly useful on the bottom shelf of wall units where they can be snapped into the adjustment holes for Adjustable Floor Glides with screw-slot bolts. They're available in styrene in colors to match your furniture.

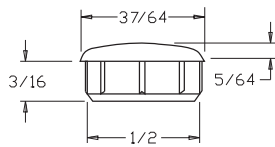

38-388

PART	COLOR	Pcs/Box	WT(LBS)
38-509	Tan, Bge, Brn	3M	32
38-388	Tan, Brn, Wal, Wht	10M	21

NYLON HOLE PLUGS

Close unneeded holes quickly, easily, and at low cost. The nylon material makes them suitable for higher temperatures. Twenty one styles are available for use in holes from 3/16" to 2-1/2" diameter. They'll lock firmly into chassis up to 1/4" thick. The convex matte finish head tapers to a thin edge. Two sizes are also available with ventilation holes. Standard colors are black or white. Other colors are available.

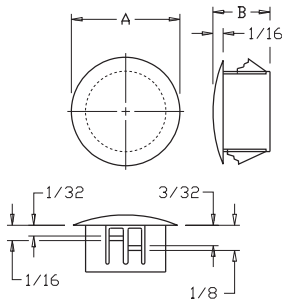

Nylon Hole Plugs

PART	FITS HOLE	A	B	Pcs/Box	WT(LBS)
H187	.187	1/4	15/64	5M	1
H250	.250	5/16	5/16	5M	2
H312	.312	3/8		5M	3
H375	.375	15/32	13/32	5M	5
H437	.437	17/32		5M	6
H500	.500	37/64		5M	7.5
H562	.562	21/32		5M	9
H625	.625	23/32		5M	10.5
H687	.687	25/32		5M	14
H750	.750	59/64	29/64	3M	10
H812	.812	57/64		3M	10
* H875	.875	1-1/64		2M	9
* H1000	1.000	1-13/64		1M	6
H1093	1.093 To 1.125	1-7/32		1M	6.5
H1187	1.187	1-5/16		1M	8
H1250	1.250	1-3/8		1M	8.5
H1375	1.375	1-1/2		1M	10
H1500	1.500	1-43/64		1M	12
H1750	1.750	1-29/32		1M	15
H2000	2.000	2-9/64	1M	18	

* Available as a Vent Plug

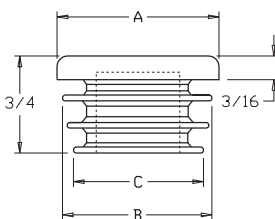

Tube Closures

TUBE CLOSURES

Handy Tube Closures have a unique "finned" design that keeps them tight in both 16 and 18 gauge tubing. You don't have to stock two sizes of closures. The black, polyethylene closures are strong enough to be used as glides, as well. Inquire for color.

PART	FIT HOLE	A	B	C	Pcs/Box	WT(LBS)
35-416	1	1.031	.934	.868	1M	10
35-417	1-1/8	1.156	1.059	.992	1M	13
35-418	1-1/4	1.281	1.184	1.118	1M	15

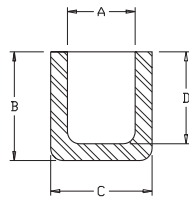

Tube Caps

TUBE CAPS

Use our plastic Tube Caps to seal ends of round tubing and cover any sharp edges. They may be used as glides on tubular legs. Tube Caps snap on easily and hold securely in either 16 or 18 gauge tubing. Available in black and natural. Made of polyethylene

PART	A	B	C	D	Pcs/Box	WT(LBS)
35-365	5/16	7/16	13/32	3/8	7M	8
35-366	1/4	3/8	3/8	5/16	9M	8
35-367	3/16	3/8	9/32	5/16	10M	6
35-368	1/8	5/16	7/32	1/4	25M	11

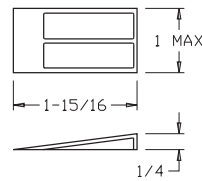

50-108

TABLE WEDGES

Handy's Plastic Wedges replace expensive wooden wedges for any drop leaf table. They'll work equally well on gate-leg, extension-base, or pull-out supports. The tough Plastic Wedges are designed to be installed with staples, which will embed themselves in the wedge below the sliding surface. Available in black, beige, walnut, 8M pcs per box-weight 43 lbs. Made of polyethylene.

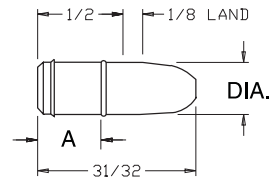

25-80

25-100

TABLE PINS

These self-lubricating Table Pins are the least expensive quality pins available. They won't shrink, swell, check or discolor tables. No glue is required for installation. Finish materials won't adhere to the pins. Use them also as top and bottom glides for sliding doors. Available in beige. Made of polyethylene.

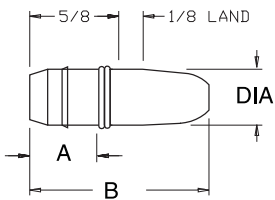

25-81

25-82

PART	A	B	DIA.	Pcs/Box	WT(LBS)
25-80	13/32	31/32	5/16	10M	20
25-100	1/4	31/32	1/4	10M	15
25-81	7/16	1-1/4	3/8	5M	17
25-82	15/32	1-5/32	3/8	5M	15
25-273 P	N/A	N/A	N/A	10M	24
25-273 L	N/A	N/A	N/A	10M	16

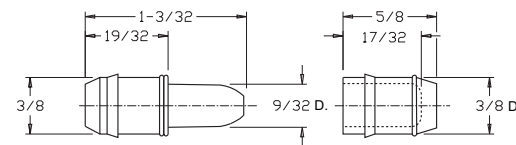
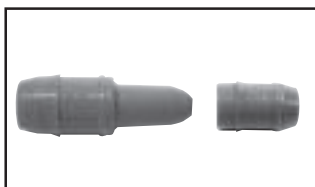

25-273 P

25-273 L

BUTTON COVERING EQUIPMENT



Junior No.1 Machine

COVERS 90 BUTTONS/HR*

This versatile, manually operated covering-cutting machine is our most popular model. Use it with Junior two-piece dies and a short cutter for peak production. A wood cutting block is included.

HEIGHT: 22"
WEIGHT: 13 LBS.



No. 2 Machine

COVERS 200 BUTTONS/HR*

This machine operates with Handy three-piece swivel dies that feed the shell and material into the top die semi-automatically.

HEIGHT: 22"
WEIGHT: 20 LBS.



No. 5A Covering Machine

COVERS 450 BUTTONS/HR*

The foot powered toggle pendulum operation frees the operator's hands for greater efficiency and speed. Use it with Handy three-piece swivel dies to produce higher quality covered buttons. Store your material on the extra wide work table for easier operation.

HEIGHT: 47"
TABLE HEIGHT: 32"
FLOOR SPACE: 20" x 23"
WEIGHT: 113 LBS.

ELECTRIC BUTTON COVERING MACHINES



No. 300 Machine

COVERS 400-1600 BUTTONS/HR*

Offering more features, easier operation and greater productivity than ever. The six-station indexing die plate is driven directly by a 1/3 hp, 90 volt DC, 60 cycle braking motor. Also -- fingertip variable speed control, automatic button counter, power indicator light, safety shield with microswitch braking control, reverse jog button, and enclosed button collection system. Durable, welded construction, easy to maintain.

HEIGHT: 51"
TABLE HEIGHT: 35"
FLOOR SPACE: 31" x 51"
AIR: 80 PSI
WEIGHT: 280 LBS.



**All rates shown are approximate*

BUTTON COVERING EQUIPMENT

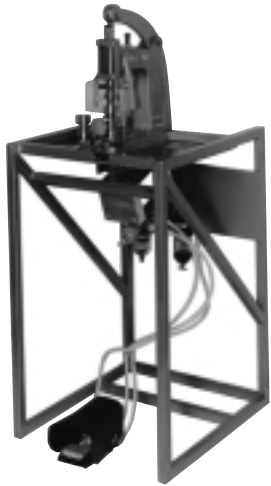

No. 5PA Covering Machine

COVERS 550 BUTTONS/HR*

Eliminates operator fatigue and boosts production while providing uniform power pressure for consistently tight buttons. The No. 5PA is pneumatically powered. Its die crimping area is protected by a safety shield.

HEIGHT: 47"
 TABLE HEIGHT: 32"
 FLOOR SPACE: 20" x 23"
 AIR: 80 PSI
 WEIGHT: 122 LBS.

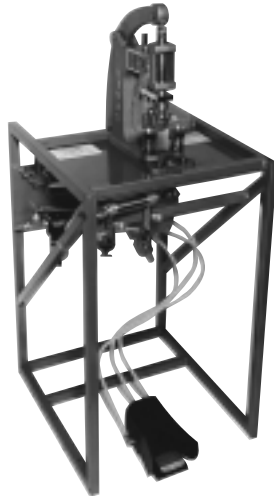

No. 7PA Auto-Swivel Covering Machine

COVERS 800 BUTTONS/HR*

As the operator depresses the foot pedal of the No. 7PA, the Handy three-piece dies swivel back and forth, enabling the operator to produce perfectly-covered buttons at maximum efficiency. A safety shield covers the die crimping area.

HEIGHT: 47"
 TABLE HEIGHT: 32"
 FLOOR SPACE: 20" x 23"
 AIR: 80 PSI
 WEIGHT: 140 LBS.



No. 9A Attaching Machine

With the proper dies, this versatile foot operated machine can be used for attaching grommets, snap fasteners, ventilators, or tacks to cap buttons. The smooth pendulum foot pedal action frees the operator's hands. The wide table has ample room for supplies and material.

Note: The No. 1, 2, and 5A Machines can also be used for attaching.

HEIGHT: 45"
 THROAT SPACE: 6"
 WEIGHT: 91 LBS.

← No. 300SH Machine

COVERS UP TO 2500 BUTTONS/HR*

The No. 300SH Machine has the features and design innovations of the No. 300 Machine with one big plus—an aluminum shell hopper for even higher production rates. With a few quick changes, the shell hopper can be adapted to feed shells from sizes 16 to 45.

HEIGHT: 51"
 TABLE HEIGHT: 35"
 FLOOR SPACE: 31" x 51"
 AIR: 80 PSI
 WEIGHT: 300 LBS.

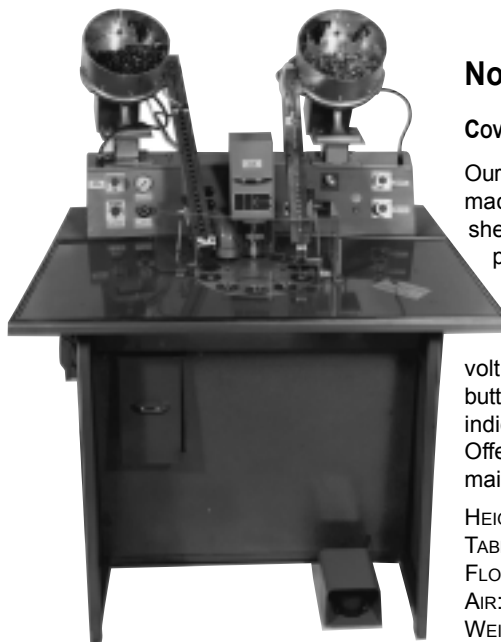

No. 400 Machine

COVERS UP TO 3000 BUTTONS/HR*

Our most advanced automatic button covering machine. With twin hoppers to feed both shells and backs, operators achieve highest production rates. A Geneva Motion Drive powers the ten-station die plate smoothly, accurately. Also: dynamic braking; fingertip variable speed control; 1/3 hp, 90 volt DC, 60 cycle braking motor; automatic button counter; reverse jog button; power indicator light and microswitch safety shield. Offers years of efficient service, minimum maintenance.

HEIGHT: 57"
 TABLE HEIGHT: 35"
 FLOOR SPACE: 35" x 45"
 AIR: 80 PSI
 WEIGHT: 450 LBS.

CUTTING EQUIPMENT, TUFTING MACHINES



Cutters

Our sharp, hardened steel cutters are available to match all dies, sizes 22 through 80. Special cutters to size 60 only are required for the 32P Machine. Replaceable cutting boards are available to fit the No. 11, 32P and 40P Machines.



No. 11 Cutting Machine

The companion cutting machine for No. 2, 5A and 5PA button covering machines. Rack and pinion design gives you smooth, easy operation. Use it with our standard long cutters. No. 11 comes with a long-lasting cutting board.

HEIGHT: 20"
WEIGHT: 60 LBS.

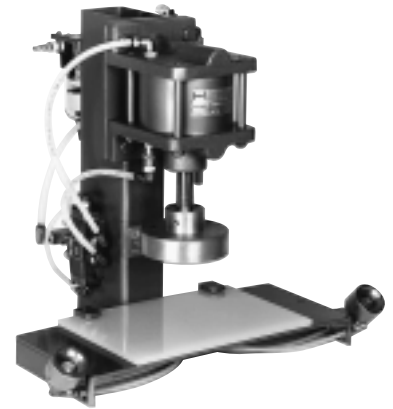

No. 40P Automatic Cutting Machine

If you need portability in a machine plus high volume, choose the No. 40P. It will fit on almost any bench or table, and the magnetic holding plate makes changing the standard long cutters an easy task. The 40P operates with a two-handed double valve, and comes complete with a long-lasting cutting board.

HEIGHT: 19"
TABLE SIZE: 23" x 15"
AIR: 80 PSI
WEIGHT: 68 LBS.

No. 32P Automatic Cutting Machine

The multiple cutouts produced with each stroke make this the most efficient fabric cutting machine available. The No. 32P has built-in safety. The operator must press palm buttons on separate valves simultaneously to activate the machine. This keeps both hands clear of moving parts.

HEIGHT: 62"
TABLE HEIGHT: 36"
FLOOR SPACE: 23" x 20"
AIR: 80 PSI
WEIGHT: 215 LBS



The Junior Tufter

Our smallest automatic tufter is perfect for reversible and semi-attached backs. It pneumatically aligns and compresses cushions up to 10" thick and 31" wide in any length, with extension channels available for longer cushions. The table moves on nylon rails with stops to easily set vertical and horizontal spacing. The Junior Tufter is available with horizontal bars to hold needles in preset patterns for stationary tufting. The basic model has three ultra-thin needles, with additional needles optional, and requires 60 psi air pressure.



The Dies You Need for Perfect Covered Buttons

Precision-manufactured dies are the key to tight, perfectly-covered buttons. Handy dies are made from high grade steel, machined, polished, case-hardened and polished again. You won't find more accurate covering dies anywhere.

Our dies accept a wide range of fabric types and thicknesses, and come in three types for light, medium, or heavy material.

Steel cutters to cut button covers are included with each set of dies. We also include covered button samples made with the dies you've ordered. Handy ships no die unless it makes perfect covered buttons.



Two-Piece Dies

Use these die sets with our Junior No. 1 Machine. Available in sizes 22 through 80 Light, Medium, or Heavy, complete with short cutter.

Three-Piece Dies

Use these die sets with our No. 2, 5A, 5PA and 7PA Machines. Available in sizes 22 through 80 Light, Medium, or Heavy, complete with a long cutter. Send a sample of your covering material with your order.

Button Covering Process

Button covering dies wrap material around the shell, and crimp the shell over the sides of the back. Drawing A shows the fabric in place over the shell in the top die. Drawing B shows the fabric wrapped under the shell by die action as the top die plunger moves down toward the bottom die. Drawings C and D show the assembly and clinching of the fabric-wrapped shell against the back. The bottom die curls the shell and fabric against the back, making the button solid and secure.

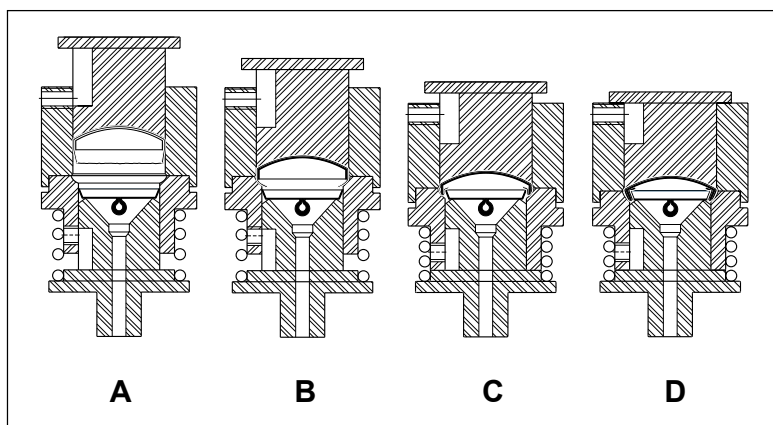
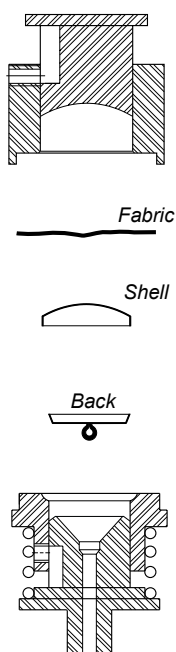

BUTTON SHELLS

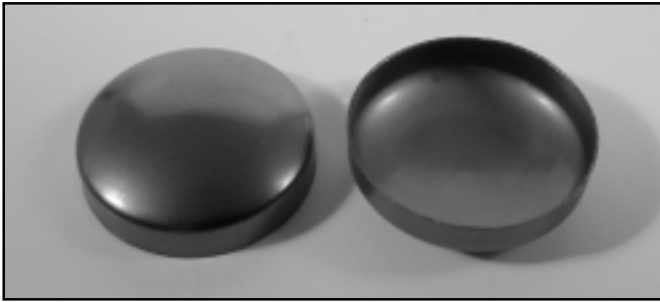

SHELL SIZE	22	30	36	40	45	60	80
BULK PKG.(GR.)	50	50	50	25	25	10	5
Wt(LBS)	8	14	18	10	13	12	9

Rust Resisting Molds

Molds (shells and backs) which resist rusting and the resulting damage to upholstery are a must for many furniture manufacturers.

All Handy metal backs are zinc plated. Standard shells are unplated, but are specially treated to resist corrosion. For extra protection, we recommend zinc plating.

Waxed Shells

Handy offers waxed shells for special requirements, particularly those of hopper-fed machines. Waxing helps shells slide easily in tracks and bowls.

Hopper Feed Shells

Handy shells are specially selected to insure that they feed and flow smoothly in your tracks and hoppers.

Shell Temper

Handy provides shells in different tempers for various fabric requirements. Our standard shell tempers are regular and soft. We can also supply harder shells for heavy or uneven fabrics, softer shells to prevent tearing delicate and vinyl material.

Scale of Button Sizes

Buttons are measured by the English standard of 40 lignes per inch. Therefore, a 30 ligne button is 3/4" diameter, a 45 ligne button is 1-1/8" diameter, and so on. The diagram shows the size of a button shell before covering.

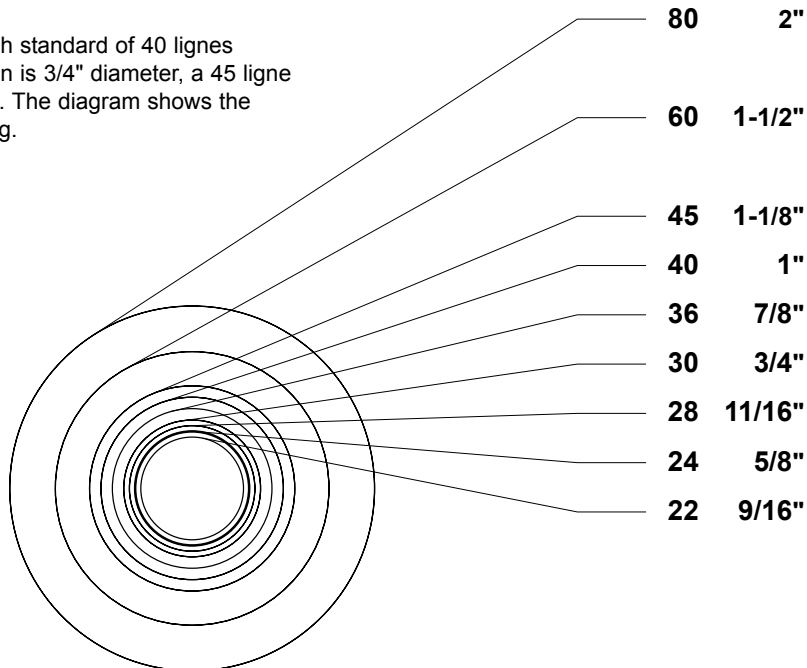

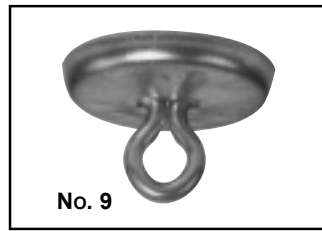

Wire Eye Backs No. 9 Standard

Handy's wire eye backs are the choice for twine tufting. The No. 9 Standard has a heavy eye and will withstand an 80 lb. pullout test. All Handy steel backs are zinc plated for rust resistance.

BTN. SIZE	22	30	36	40	45	60	80
Bulk Pkg.(Gr.)	50	50	50	25	25	10	5
Wt(lbs)	12	22	28	17	19	12	11



Wire Eye Backs No. 44 Small

The No. 44 has a smaller eye to be used against delicate materials to minimize piercing and runs. All Handy steel backs are zinc plated for rust resistance. No. 44 Backs are also available in aluminum.

BTN. SIZE	22	30	36	40	45	60	80
Bulk Pkg.(Gr.)	50	50	50	25	25	10	5
Wt(lbs)	12	22	28	17	19	12	11



Button Replacement Kit

To replace buttons quickly and easily, thread twine through a needle-pointed anchor and insert anchor in tufting needle. Punch tufting needle through padding, holding twine ends back. When Tufting Needle is withdrawn, point releases and snaps in position as permanent anchor. Tie a button on loose twine ends to restore tuft. Tufting Needle and 100 needle points in kit. Refills are available, 1000 per box.

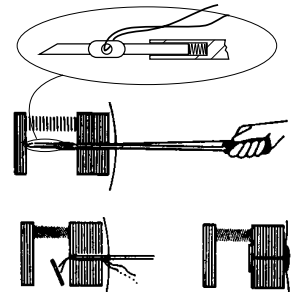

Tufting Twines

This tufting twine is an exclusive design which meets the most demanding upholstery construction needs at a low cost. It's manufactured from 100% first quality white virgin nylon with a non-slip finish to end slipping finish knots and frayed ends. Strong and highly abrasion-resistant.



Twine

Handy offers a full range of twines in nylon, rayon and cotton. They're available on 45 lb. reels with 50 ends to save time and labor; 50 lengths of twine can be cut at one time to any desired length.

PART	YIELD/LB	BREAKING STRENGTH	PUT UP
Handy Tie Nylon	2200'	92 Lb	45 lb. reels
			2 lb. tubes
			1/2 lb. dispenser
25203 Nylon	2195'	91Lb	45 lb. reels
			2 lb. tubes

NAIL BUTTON BACKS, WASHERS & PRONGS

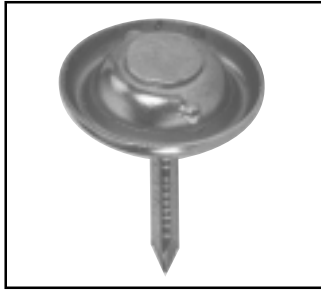

No-Dent Corrugated Nail Backs

Our button backs are welded to heavy duty 13-gauge corrugated nails. They're designed to be driven through fabric and into frames without special tools. The steel backs are formed to support the shell and prevent denting. Inquire about nail driving tool.

BTN. SIZE	22	30	36	45	60
BULK PKG.(GR.)	25	25	25	25	10
NAIL LGTH.	WT(LBS)				
3/4"	12	16	20	30	18
1"	14	18	22	32	19
1-1/4"	16	20	24	34	20
1-1/2"	18	22	26	36	22

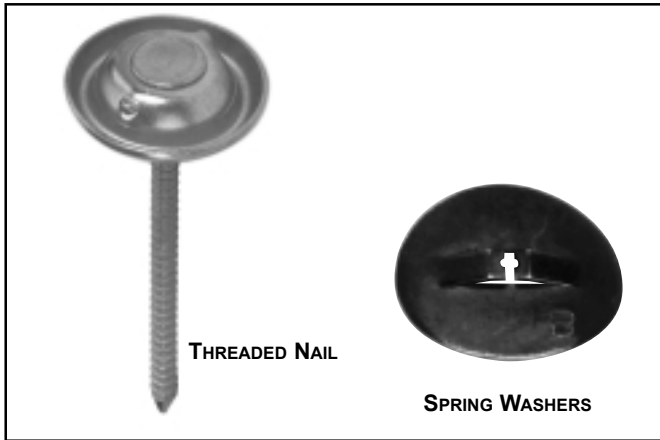

Threaded Nail Back & Spring Washers

When anchored with a spring lock washer, the Threaded Nail is a fast, positive, alternative to prong tufting. Just insert the nail through the upholstered construction and fasten it on the back with a **No. 15 Spring Washer**. This 15/16" diameter washer manufactured of high quality spring steel, provides a secure anchor for a tuft when locked on to a threaded nail. Rounded edges, no sharp corners. The spring washer is boxed 25 gr. and weighs 14 lbs.

BTN. SIZE	22	30	36	45	60
BULK PKG. (GR.)	25	25	25	25	10
NAIL LGTH.	WT(LBS)				
5/8"	9	14	18	25	
7/8"	10	15	19	26	17
1-1/2"	14	19	22	32	
2"	17	22	27	14	



Welded Serrated Studs & Retainers (for styles with buttons on both sides)

Our serrated heavy duty stud nails are stronger than conventional types. Button backs are securely welded to the nails. After covering, the buttons are pushed or driven through upholstered panels. Retainer snaps on to lock the button in place.

BTN. SIZE	30	36	45
BULK PKG (Gr.)	25	25	25
STUD LGTH.	WT(LBS)		
3/4"	19	22	28
1"	22	25	31
1-1/2"	28	31	37
2"	34	37	43
STUD RETAINER			
	5	8	11



Prongs

Prong button tufting is fast, economical and secure. It eliminates many twine tufting operations, and requires no special skills or button dies. The prong is anchored in place by bending the flatwire legs over a prong washer in the padded back.

BTN. SIZE	22	24	30	36	40	45
BULK PKG.(GR.)	25	25	25	10	25	10
PRONG LGTH	WT(LBS)					
1-1/2"	16	18	22	26	36	38
2"	19	21	26	30	40	42
2-1/2"	22	25	30	34	44	21
3"	25		15	17		21

* Also available in size 50-100 (unassembled)

PRONGS & WASHERS & PIVOT BUTTONS

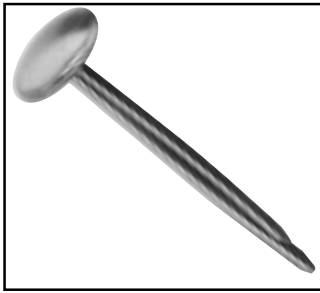

Finished Metal Buttons

These assembled buttons are available in standard sizes with prong or wire eye backs. Inquire for other special assemblies. Finishes: Brushed Brass, Bright Gold, Nickel.

BTN. SIZE	24	30	36
BULK PKG. (GR.)	5	5	5
PRONG LGTH.	WT(LBS)		
1-1/2"	6	7	8
2"	6	7	8
2-1/2"	7	8	9



Prong Button Tufting Tool

Make prong button tufting easier with our Prong Button Tufting Tool. Use it with any size button or any length prong. The tool is withdrawn after piercing, leaving the prong legs extended through the fabric. It prevents spreading prong legs during insertion.

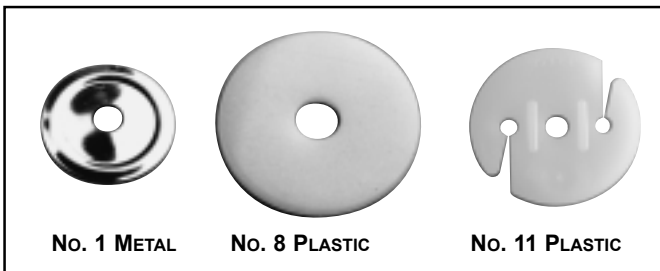

Prong Washers

Use any of our washers to lock buttons firmly in place. They are available in metal or polyethylene in diameters from 15/16" to 1-3/8".

The polyethylene washers help deaden noise resulting from contact with springs.

PART	DIA.	WT(LBS)
No. 1	15/16"	14
No. 8	1-3/8"	17
No. 11	1-1/8"	15

WT(LBS) for 25 Gross

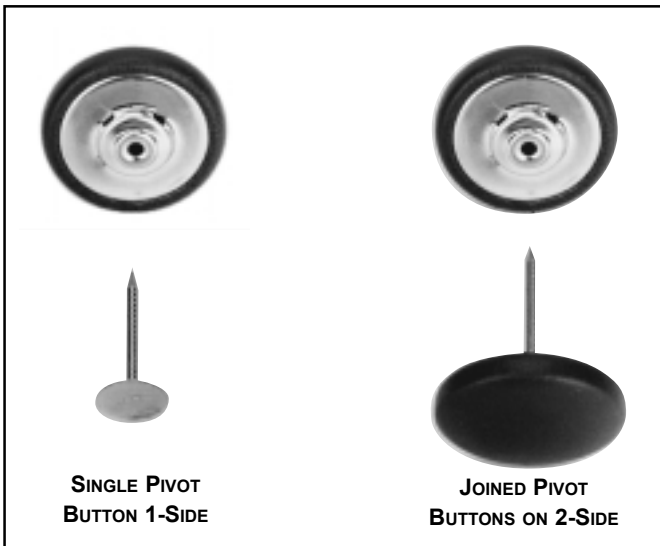

Single & Joined Pivot

The single Pivot female half comes with separate serrated tacks. Use it where a button is on one side of a cushion or to tailor skirts. For covered buttons on both sides of a cushion, use our Joined Pivot, supplied in pairs. The female half is assembled with a retaining pivot spring steel lock washer which mates with the serrated pivot tack of the male half. Easily snapped together, the buttons hold tight. Inquire about size and availability. Minimum quantities may apply.



Nylon Hook Backs

Streamline your tufting operation, eliminate hand tying with Handy's unique Nylon Hook Back. Pre-tied loops or Fastufts snap easily and securely into the patented dual-locking hook, and assure uniform tufting depth.

BTN. SIZE	22	30	36	40	45	60	80
BULK PKG.(GR.)	50	50	50		25	10	5
WT(LBS)	8	14	20		14	12	11

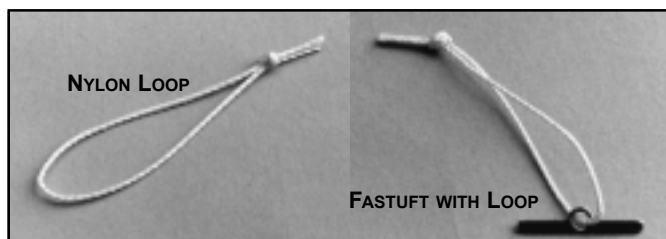

Nylon Loops

Our twine loops are pre-measured and pre-tied. No. 8402 is standard nylon and No. 8403 is heavy nylon.



Fastuft with Loop

The Fastuft is a complete ready-to-use tufting system for tight seat backs and non-reversible cushions. The pre-tied nylon loops with attached steel retaining clips produce a uniform and secure tuft. To use, simply snap or loop the Fastuft onto the button, carry the clip through the cushion with Fastuft needle, and release. Machine tied w/free floating knot. Available size 1-5/8" to 8".

PART	PKG.	WT(LBS)
Nylon Loop	5000 Pcs (10 Bundles)	2
Fastuft with Loop	5000 Pcs (20 Bundles)	10

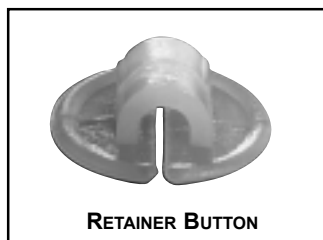

No. 11 Tufting Disc w/Ribs

Use this size 1-1/8" diameter polyethylene Tufting Disc to anchor pre-tied loops on the blind side. Reinforcing ribs add strength and reduce flexing.

No. 28 Split Retainer Button

PART	PKG.	WT(LBS)
# 11 Tufting disc	25 Gr.	6
28-Retainer Button	2000 pcs	3



Finished Hook Button

Handy's attractive size 40HB Finished Hook Button simulates an upholstered button. Weather-proof nylon, available in white. Inquire about colors. 25 gross per box; weight 18 lbs.

Tufting Needles for Loops & Fastufts

Push-Thru needles have handles for pushing twine loops through the work and attaching a retainer. Pull-Thru types have no handles; needle is pulled through work before attaching retainer.

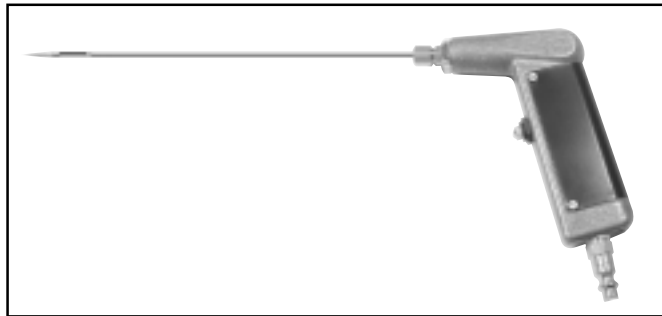
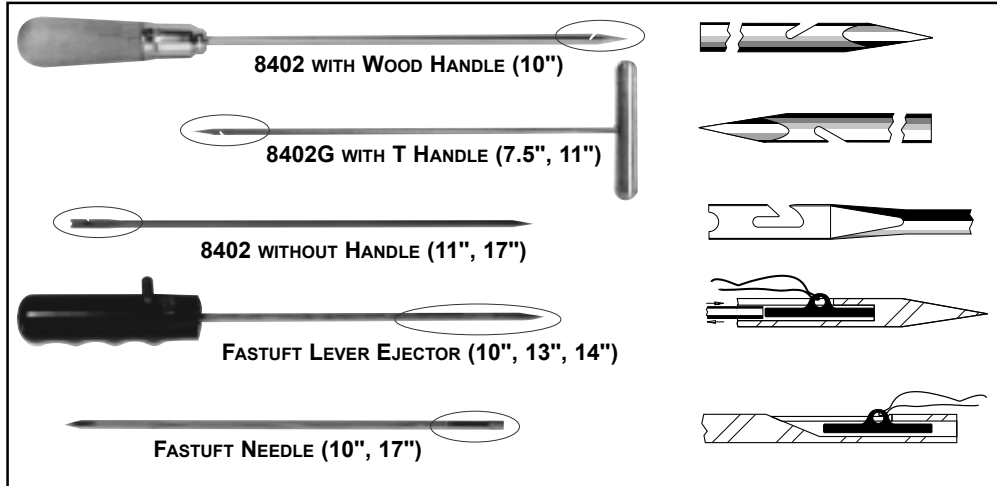

Air Powered Ejector Needle for Fastufts & Tapes

Handy's air powered ejector needle is the easiest way to install #100 and Euro mattress tufting tapes, and Fastufts. The air powered plunger ejects the clip from the needle. Available in 9", 14" and custom lengths.

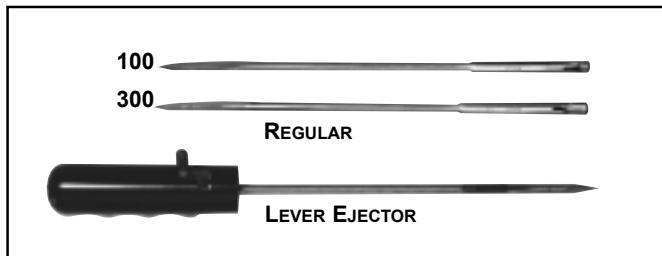

Tufting Tape Needles #100 Regular

These extra sharp tufting needles are available in 10" or 17" lengths. The clip is easily released when the needle is brought parallel to the work.

#100 Lever Ejector Needles

Reduce tufting time up to 60% with these 10" or 14" needles. Clips are held in the needle slot and released by lever control.

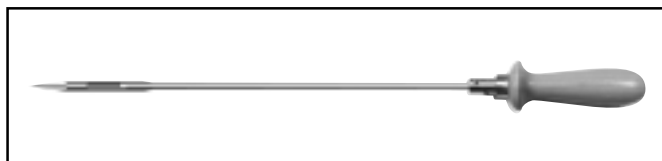

Euro Tape Ejector Needle

Handy's Euro ejector needle allows adjustable tension pressure on the clip, which simplifies the tufting process. In one swift motion the needle can be used to install Euro mattress tapes. 13" length.

FINISHED BUTTONS & SNAPS

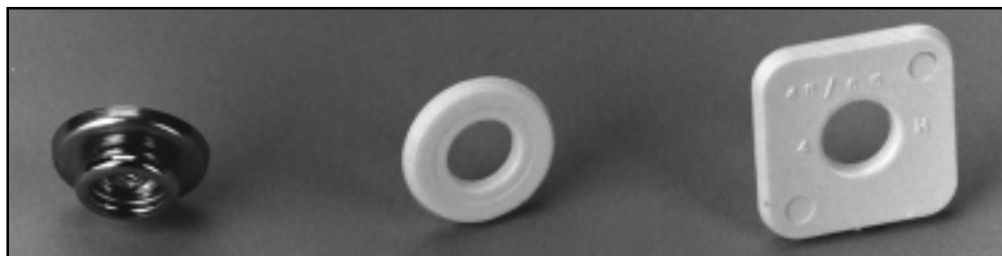

PART	PKG.(GR.)	WT(LBS)
ASSEMBLED SNAP BUTTON		
	25	24
ONE PIECE DURASNAP		
SIZE 30	25	3
SIZE 36	25	6
SQUARE DURASNAP		
	5	7

Assembled Snap Button

Handy offers a full line of Snap Buttons which can be covered on standard dies. The Snap Button, assembled with a socket, mates with a stud or a wood screw stud. Assembled with stud, it mates with a socket. Or use the One Piece DuraSnap which mates with a stud or wood screw stud.

One Piece DuraSnap

This nylon back snaps onto a Durable Wood Screw or Durable Stud when covered. Cover the DuraSnap normally, screw the stud into upholstered panel and snap covered DuraSnap over it. Economical DuraSnap provides a secure hold, resists rust and discoloration.

Square DuraSnap

Like the regular DuraSnap, the 1-1/4" Square DuraSnap has a unique, one piece design with easy-on-stay-on snapping action.

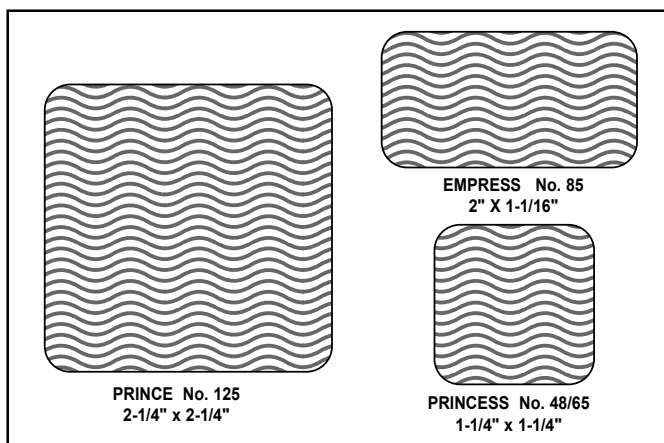

Designer Buttons

For a distinctive and dramatic look in upholstered furniture, square, oblong, and contoured buttons are available in the sizes and shapes shown. Choose from wire eye, prong, or nylon hook back (Princess); prong or wire eye (Prince, Empress). Bulk or boxed. See Price List for special covering dies.

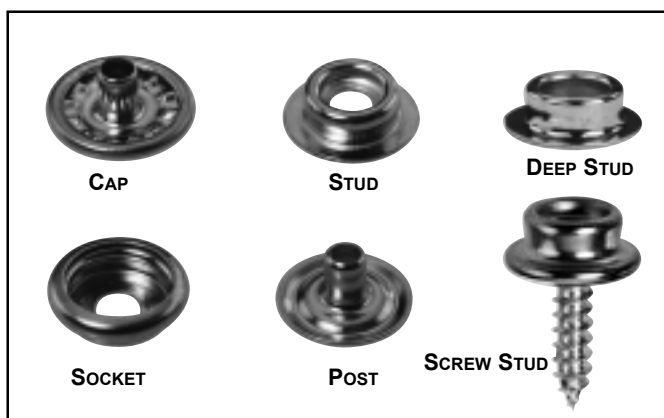

Durable Fasteners

Handy Durable Fasteners are heavy duty (19/32" O.D.) snaps for upholstery fabrics. Nickel plated steel or, for rustproof applications, nickel plated brass. Use the Cap and Socket with the Screw Stud, available in 3/8", 5/8", or 1" lengths, Regular or Deep. Use the Deep Stud with your own screws.

It won't distort when the screws are tightened down. Screw the stud into the wood panel or furniture frame, then snap the assembled socket and cap over it.

PART	Pcs/Box	WT(LBS)
* Cap	1M	2
* Socket	1M	2
* Stud	1M	2
* Post	1M	2
Screw Stud	1M	6
Deep Stud	1M	2

* Also available in 100 Pcs/Box

Handy Euro Mattress Tapes

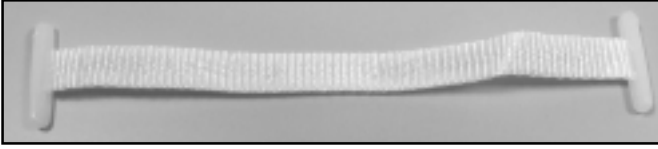

Handy's nylon mattress tufting tapes with 7/8" molded plastic clips at both ends are widely used for futon and mattress tufting. They can stand alone or be anchored with felt washers and/or rosettes. Install with Handy #100 regular or ejector needles. Available in 1/2" increments from 1" and up. Inquire about special colors.

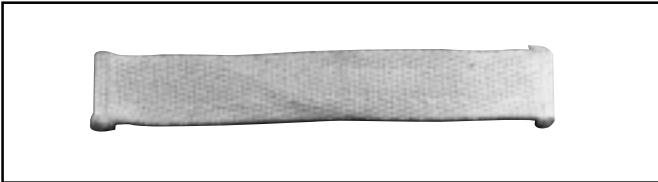

100 Tufting Tapes

Our pre-measured Tufting Tapes and Straps offer easy, uniform, and durable hand tufting. No. 100 tapes are 11/16" wide with 5/8" clip at each end. Straps have a clip and a button or buttons at each end. Offered in 1/2" increments, lengths of 1-1/2" to 9". Tufting needles shown in page 13. Our #100 needle is used with our #100 tapes. 1M pcs per box.

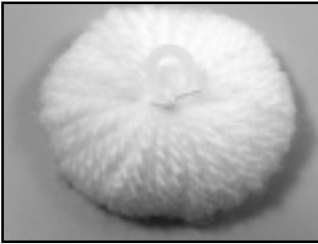

Rosettes

Handy's Rosettes can be easily attached with Handy Euro Tapes. They can be cut open to create a pompon appearance. Available in white and cream.

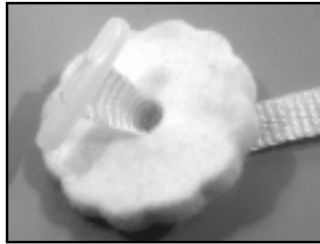

Felt Washers

Handy's Small and Large felt washers can be attached with Handy #100 and Euro Mattress Tufting Tapes. Available in white.



Mattress Tufting Buttons

Handy's Mattress Tufting Buttons are molded plastic and designed for use in the United Mattress Button Tufting Machine. Available in gray and white.



Ventilators, Handle Grommets and Eyelets

Our solid brass ventilators have a beveled under-edge which holds firmly to any ticking, plastic or fabric. Use washers for thinner materials. Gold color and nickel finishes.

PART	I.D.	O.D.	SHK.	Pcs/Box	WT(LBS)
1B Vent.	9/16	3/4	3/16	1M	4
1BL Vent.	9/16	3/4	19/64	1M	5
#1 Washer	9/16	3/4	N/A	1M	1
2B Vent.	49/64	1	1/4	1M	8
2BL Vent.	49/64	1	11/32	1M	9
#2 Washer	49/64	1	N/A	1M	1



Handy can create just the right grommet or eyelet for any mattress application.

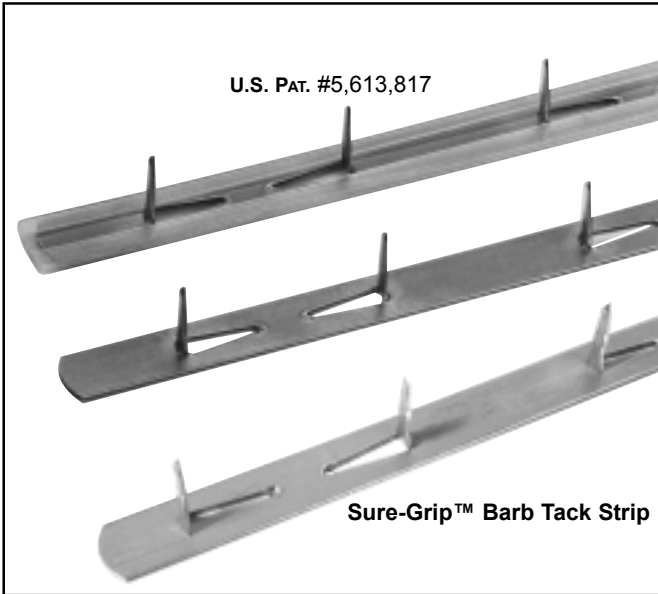

Velvet Edge™ Tack Strip

Tough, tempered steel Velvet Edge™ Tack Strip has softly rounded edges. It is gentle on your most delicate materials, and won't snag or tear materials in assembly and shipment. With its slim profile, the Velvet Edge™ disappears under fabric. Seams look hand sewn. You can buy tack strips anywhere, but Velvet Edge™ is available only from Handy Button. For added protection for material, we offer this tack strip assembled with a plastic sleeve.

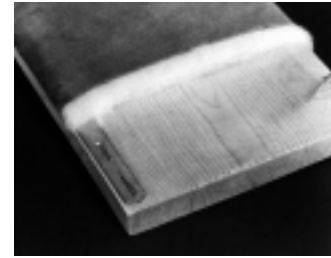

Sure-Grip™ Barb Tack Strip

Ideal for soft wood and plywood frames, "Xmas tree"-shaped tacks anchor into the frame, won't loosen or pull out. Upholstery stays tight.

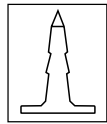

TACK SIZE	STRIP LENGTH	PKG.
#6	3" to 5"	2000 Strips
#8	5-1/2" and up	500 Strips
#10	TACK STRIP WITH PLASTIC SLEEVE	
#12	6-1/2" to 36"	400 Strips

Increments of 1/2"

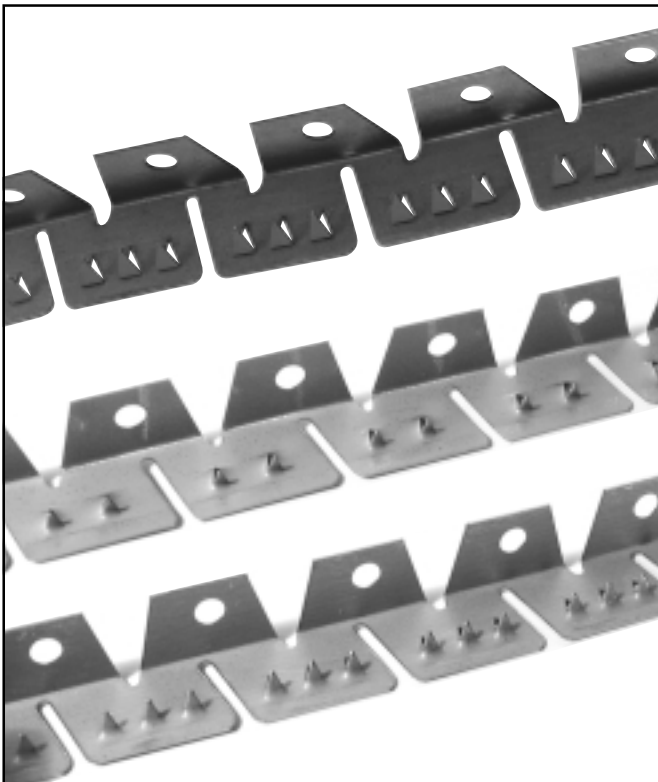

Flextrim

Handy offers a flexible tacking strip for every need. Flex-Trim, Pli-Grip and Fabri Fast are available in two or three tooth versions, regular and heavy weights.

DESCRIPTION	PKG.	WT(LBS)
Regular	500 Ft. in 5 Reels	16
Heavy	500 Ft. in 5 Reels	20



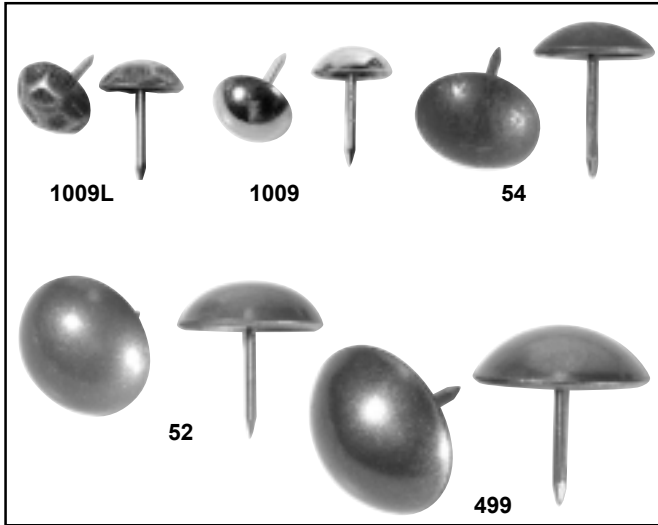

Decorative Nails

Decorative Nails add a distinctive designer's touch. Nickel, Gilt, French Natural or Relieved Antique finishes with brass or steel heads. Standard shank length is 1/2". Also available in 3/8", 5/8", and 3/4" lengths. We supply nails with a beveled edge for nail guns.

PART	Pcs/BOX	WT(LBS)
1009L	1M	3
1009	1M	3
52	.5M	2.5
54	.5M	4.7
499	.5M	7.5

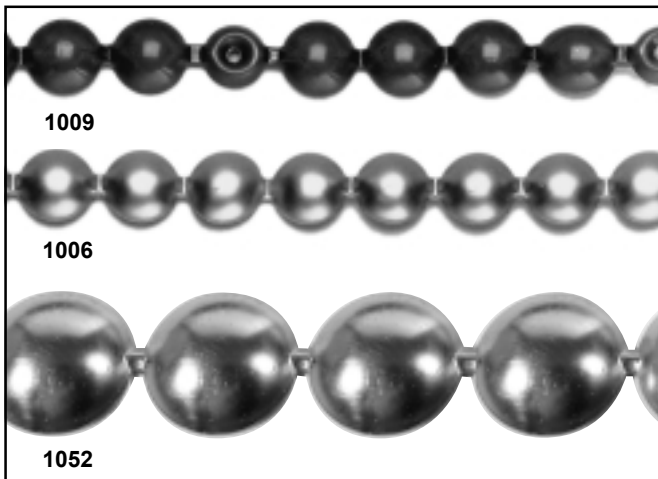

Nail Strips

Our solid steel Continuous Nail Strip simulates No. 1009 and 52 nails. The No. 1009 strip has four simulated nails followed by a space for an actual nail. Staples are used between the heads on the No. 1006 and 1052 strip, eliminating the need for nails. Finishes available: Gilt and French Natural. 8000 #1009 nails are required for one case of 1009 nail strip.

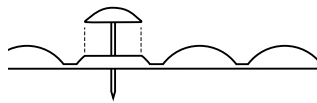

PART	PKG.	WT(LBS)
1009	500 Yds.	29
1006	(10 Rolls)	
1052	250 yards	

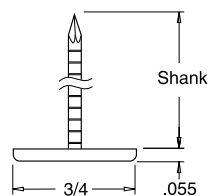

Panel Nails

Use our Panel Nails on chair arms to secure upholstered panels to the front of arms. Insert the nails between two panels of cardboard. Cover the panels with upholstery material and nail them to the arms. 1-1/8" threaded Panel Nails offer additional holding strength.

SHANK SIZE	Pcs/BOX	WT(LBS)
7/8"	5M	38
1-1/8"		40

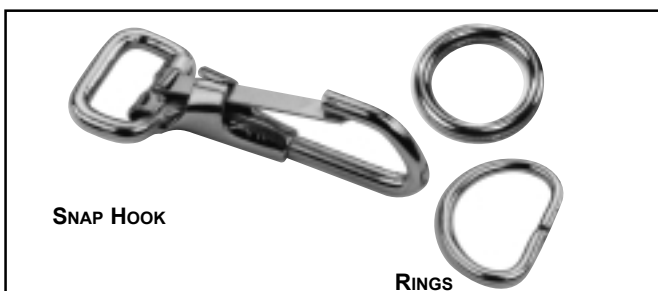

Snap Hook and Ring

This combination is an economical method for fastening detachable cushions with a strap. They're available in a wide variety of finishes.

Round Rings, D-Rings

These useful rings, either wire or cast, are available in a wide variety of finishes in sizes up to 2". Please inquire.

CLIPS, RINGS & GROMMETS

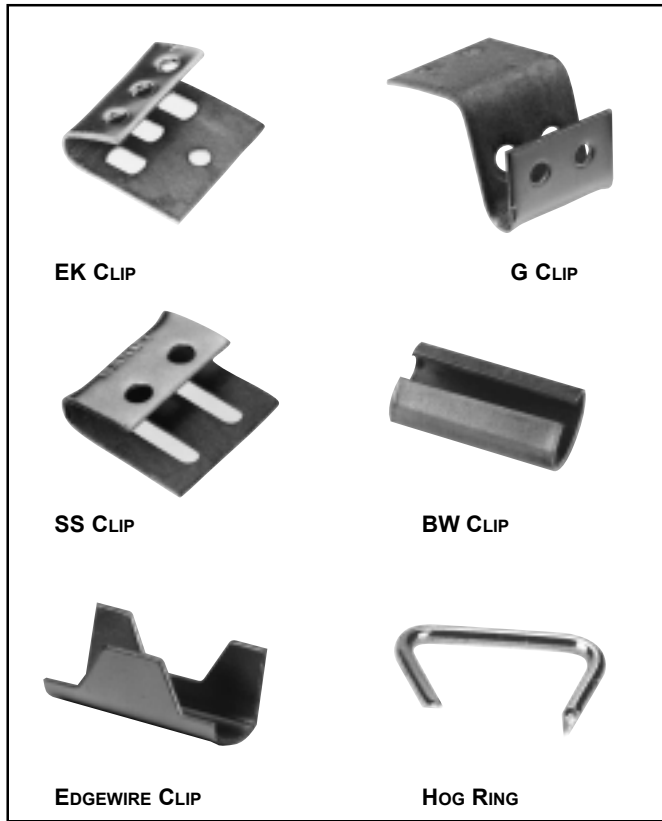

Clips

Handy's 7/8" wide Zig Zag Clips are fully paper lined that resist spring abrasion. Heavy steel construction keeps clips from opening when springs are in tension. Secure the clips from any angle. They hold zig zag springs of any gauge permanently.

The universal four-hole **EK Clip** is used for back and seat construction. Use either one or two nails on the lip. The **G Clip** allows the spring to drop 7/8" below the rail top. Fasten the clip to the top and inside of the rail with nails or staples.

Use the universal **SS Clip** with a staple gun for back and seat construction. Use fully lined, solid steel **BW Clips** to attach zig zag, edge and torsion springs to any gauge of border and edge wires. 7/8" x 1/2". Plasticized lining resists spring abrasion. Closing pliers available.

Edgewire Clip construction is a Handy specialty. The cold rolled steel clips have no burrs or sharp edges.

Hog Rings

Our 3/4" 14 gauge Hog Rings can be used for attaching burlap, sisal pads, seat covers, etc.

PART	Pcs/Box	WT(LBS)
EK CLIP	5M	50
G CLIP	2M	36
BW CLIP	600	62
SS CLIP	4M	47
Edgewire Clip	2075	25
Hog RING	10.2M	25

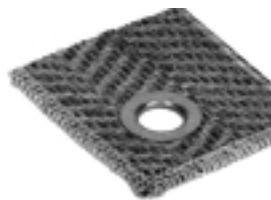
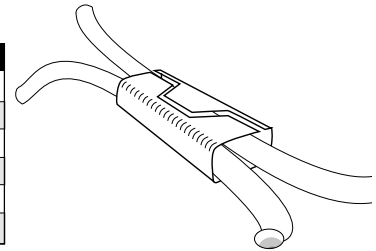

Swatch Grommets

The No. 25 Flat Steel Grommet and Washer is made specifically for fabric sample displays. It is thin and flat to allow more samples per rack. Available in gilt and nickel finish.

GROMMETS #	O.D.	I.D.	PKG.(GR.)	WT(LBS)
25 Flat steel	7/8	1/2	25	7
25 Washer	7/8	1/2	25	5

Also available in 5 Cross Box



Brass Grommets

These solid brass grommets and washers are available in sizes 0-5, in gilt or nickel finishes. See table for weights.

SIZE	O.D.	I.D.	PKG.	WT(LBS)	
				GROMMET	WASHER
0	9/16	1/4	25 (Gr.)	4	2
1	11/16	9/32		7	4
2	13/16	3/8		8	5
3	1	7/16		14	6
4	1-1/16	1/2		21	8
5	1-3/16	5/8		28	12

Also available in 5 Cross Box

Plastic Nail Glides

Handy's Plastic Floor Glides won't rust or mar floors, are easily installed with a hammer, and provide easy sliding action. They're available with oval or flat heads with a wide variety of diameters.

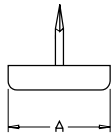

Flat Head

PART #	A	COLOR	PKG.(GR.)	WT(LBS)
234-1050-585	5/8	bge	5M	18
234-1050-735	5/8	nat	5M	18
234-1060-585	3/4	bge	5M	20
234-1060-735	3/4	nat	5M	20

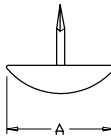

Oval Head

PART #	A	COLOR	PKG.(GR.)	WT(LBS)
234-0040-585	1/2	bge	5M	12
234-0040-735	1/2	nat	5M	12
234-0050-585	5/8	bge	5M	15
234-0050-735	5/8	nat	5M	15
234-0060-585	3/4	bge	5M	18
234-0060-735	3/4	nat	5M	18
234-0070-585	7/8	bge	5M	19
234-0070-735	7/8	nat	5M	19

One- and Three- Prong Metal Glides

Available in tough or case hardened steel. The One-Prong Glide is available nickel plated or roll-polished. The Three-Prong Glide is available bright zinc plated or roll-polished. Most sizes are also available in stainless steel. (See table.)

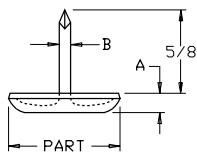

1-Prong Glides

1-PRONG GLIDES				
PART	A	B	Pcs/Box	WT(LBS)
* 1/2	1/8	.064	4M	12
* 5/8	9/64	2.0MM	4M	26
* 3/4	9/64	.080	4M	44
* 7/8	9/64	.080	4M	51
1	9/64	.080	2M	33

* Available in stainless steel.

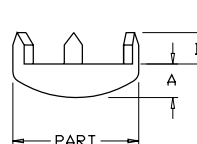

3-Prong Glides

3-PRONG GLIDES				
PART	A	B	Pcs/Box	WT(LBS)
1/2	3/16	3/16	4M	19
* 5/8	13/64	15/64	4M	28
* 3/4	13/64	1/4	4M	32
* 7/8	1/4	15/64	4M	44
1-1/8	7/32	15/64	2M	26
5/8 Deep	9/32	15/64	4M	33
3/4 Deep	9/32	15/64	4M	44

FLOOR GLIDES

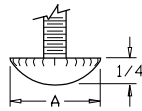

Type B Oval Base Glides

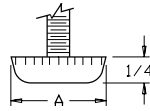

Type B Flat Base Glides

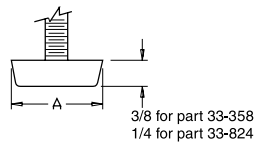

Type C Glides



TYPE B OVAL BASE GLIDES

PART	A	THREAD	COLOR	Pcs/Box	Wt(LBS)
33-124	5/8	1/4-20 x 1 LG.	Bge, Nat	1M	15
• 33-131	7/8	1/4-20 x 1 LG.	Bge, Nat	1M	18
33-132	1	1/4-20 x 1 LG.	Bge, Nat, Blk	1M	20
33-133	1-1/8	1/4-20 x 1 LG.	Bge, Nat	1M	22
33-139	1-1/8	1/4-20 x 5/8 LG.	Bge, Nat	1M	18
33-345	1-1/8	1/4-20 x 1/2 LG.	Bge, Nat	1M	11
33-356	5/8	1/4-20 x 5/8 LG.	Bge, Nat, Blk	1M	11
33-359	5/8	1/4-20 x 7/16 LG.	Blk	1M	11
33-364	1-1/8	1/4-20 x 1-1/2 LG.	Bge, Nat	1M	13
•• 33-6027	1-1/8	1/4-20 x 1-1/2 LG.	BGE	1M	25

TYPE B FLAT BASE GLIDES

• 33-130	3/4	1/4-20 x 1 LG.	Bge, Nat, Blk	1M	18
33-232	1	1/4-20 x 1 LG.	Blk	1M	21
33-235	1-1/8	1/4-20 x 1/2 LG.	Blk	1M	20
• 33-5322	1	5/16-18 x 1-5/8 LG.	Nat	500	27

TYPE C GLIDES

33-358	1-1/8	5/16-18 x 1-1/2 LG.	BGE, NAT, BLK	500	24
33-824	1/2	#6-32 x 3/4 LG	NAT	5M	23

• Glide available with T-Nut only

•• Screw slot

Support Bracket

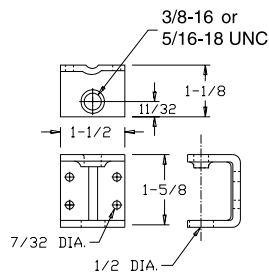
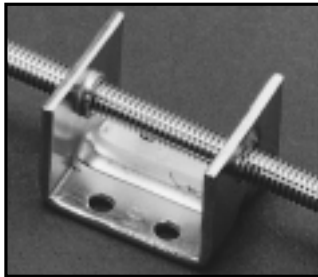

SB-8038-15

Corner Brace

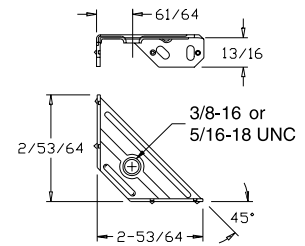

CB-9038-15

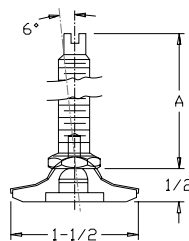

Swivel Adjustable Levelers

Swivel Adjustable Levelers

These levelers give you extra flexibility with a bolt that swivels in the base to 6° from vertical. The nickel plated 3/8-16 bolt is slotted at the top and has a hex shoulder at the bottom for adjustment from inside or outside the cabinet. Made of polyethylene.

PART	THREAD	A	Pcs/Box	Wt(LBS)
33-7500	3/8-16	1-1/2	250	16
33-7510	3/8-16	2-1/2	250	22
33-7520	3/8-16	3	250	25
33-7530	3/8-16	3-1/2	250	27
33-7540	3/8-16	4	250	29

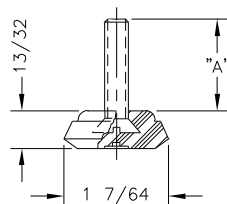

33-4000 SERIES

NON-SKID GLIDES

Handy's new 33-4000 series of non-skid glides combines tough durability with a special engineered thermo plastic that greatly reduces the sliding movement of the glide. Helps to keep furniture in place and stands up well to heavy loads.

PART	THREAD	A	Pcs/Box	Wt(LBS)
33-4030	1/4-20	3/4	1M	23
33-4040	1/4-20	1	1M	26
33-4130	5/16-18	3/4	1M	30
33-4140	5/16-18	1	1M	35

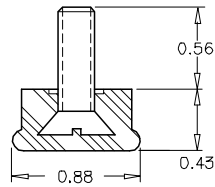

33-8315

Nylon Base w/black Screw

This black nylon base glide has a black screw that blends in with most recliner bases. Can be installed with air-drivers. The 1/4-20 thread screw is black oxide finish. 1M pcs per box-weight 20 lbs.

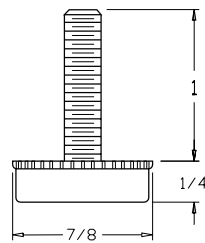

33-5340

The Heavy Duty Nylon Base Glide

This nylon base, with its 5/16-18 x 1" screw, supports the heaviest pieces. The 7/8" base lets you set shelving units flush together. Available in black, 1M pcs per box-weight 30 lbs.

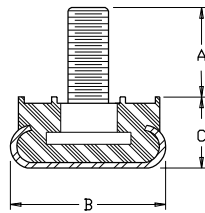

RG 100 SERIES

RG Metal Base Cushion Glides w/screw

Our special design keeps the screw from turning in the polypropylene cushion.

SCREW WITH 1/4-20 THREAD					
PART	A	B	C	Pcs/Box	Wt(LBS)
RG 105	1/2	7/8	13/32	1M	27
	3/4	7/8	13/32	1M	32
	1-1/8	7/8	13/32	1M	35
RG 110	1/2	1-1/16	13/32	1M	36
	1-1/8	1-1/16	13/32	1M	43
RG 115	1	1-1/4	13/32	500	22
SCREW WITH 5/16-18 THREAD					
RG 105	1	7/8	13/32	1M	35

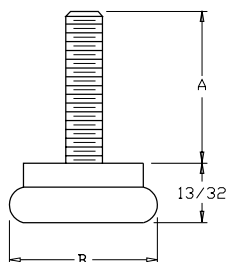

33-8000 SERIES

Cushion Glides w/screw

Non-rusting and economical. Made of polyethylene. For added durability inquire about nylon plastic base.

SCREWS WITH 1/4-20 THREAD				
PART	A	B	Pcs/Box	Wt(LBS)
33-8010	1/2	1	1M	19
33-8030	3/4	1	1M	22
33-8060	1	1	1M	25

FLOOR GLIDES & T-NUTS

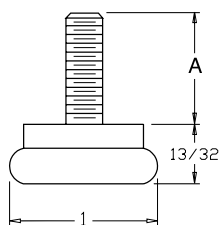

33-8010 **33-8030**

The Glide That Hides

If you want your furniture to look like it's floating above the floor, Handy's new clear plastic glides do the trick. Available with 1/4-20 x 1/2" and 3/4" screws.

PART	A	Pcs/Box	WT(LBS)
33-8010	1/2	1M	20
33-8030	3/4	1M	23

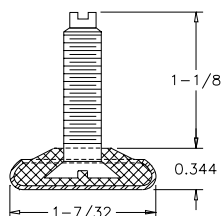

33-5500

Metal Base Heavy Duty Leveling Glides

Strong black oxide steel base with 5/16-18 x 1-1/8" slotted bolt. Strong enough to handle the heaviest loads. 500 pcs per box--weight 23 lbs.

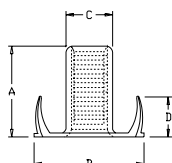

T-Nuts

T-NUTS

Multi-prong and propeller T-Nuts have slightly beveled and tapered barrels for easy insertion. Plain steel or zinc plated.

PART	THREAD	A	TYPE	B	C	D	Pcs/Box	WT(LBS)
58129	10-24	9/32	3 PRONG	3/4	.230	1/4	5M	30
59038		9/32	6 PRONG	3/4	.230	1/4	5M	30
756		13/32	6 PRONG	3/4	.230	1/4	5M	36
59045	10-32	9/32	6 PRONG	3/4	.230	1/4	5M	30
59013		5/16	3PRONG	3/4	.305	1/4	5M	39
59015	1/4-20	5/16	6PRONG	3/4	.303	1/4	5M	39
58696		7/16	3 PRONG	3/4	.306	3/8	5M	45
936		7/16	6 PRONG	3/4	.306	1/4	5M	46
58686		9/16	3 PRONG	3/4	.306	3/8	3M	31
59028	5/16-18	7/16	PROPELLER	3/4	.306	N/A	2M	46
58703		3/8	4 PRONG	7/8	.385	1/4	2.5M	34
59044		3/8	6 PRONG	7/8	.385	9/32	2.5M	34
58753		5/8	3 PRONG	7/8	.389	7/16	2M	36
58708		5/8	4 PRONG	7/8	.389	9/32	2M	36
59053		3/8-16	7/16	6 PRONG	1	.453	3/8	1.3M

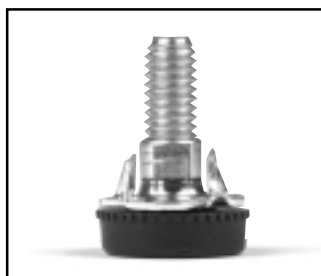

Handy All-In-One Glide-T-Nut Assemblies

Cut Costs, Save Installation Time

The threaded insert is already screwed onto the glide. All-In-One assemblies are economical as well. And they are available with any of Handy's big line of floor glide--basic screw glides, cushioned glides, heavy duty insulated glides, adjustable glides, heavy duty leveling glides and self-leveling glides. Also available with propeller T-Nut.

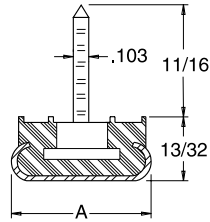

RG 105 **RG110**

RG Metal Base Cushion Glides

Hard steel base with plastic cushion provides the highest level of durability.

PART	TYPE	A	Pcs/Box	Wt(LBS)
RG 105	REGULAR	7/8	1M	27
RG 110	REGULAR	1-1/16	1M	34

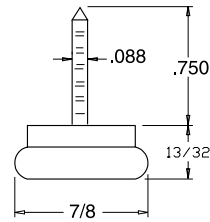

33-8100 **33-8200**

Cushion Glides

Non-rusting, economical and durable. Choose from polyethylene, or nylon when extra durability is needed. Available in black.

PART	TYPE	Pcs/Box	Wt(LBS)
33-8100	REGULAR	2M	17
33-8200	NYLON	2M	17

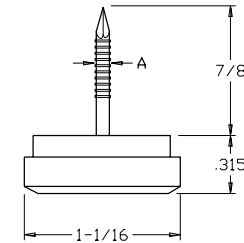

Heavy Duty Insulated Glides

Heavy Duty Insulated Glides

The 33-9100 and 33-9300 Insulated Glides have an extra tough nylon base and come with standard or threaded nails. With these glides, heavy furniture can be slid over a rough floor surface without damage to the bases. Available in black.

PART	TYPE	A	Pcs/Box	Wt(LBS)
33-9100	REGULAR NAIL	.090	1M	16
33-9300	THREADED NAIL	.095	1M	16

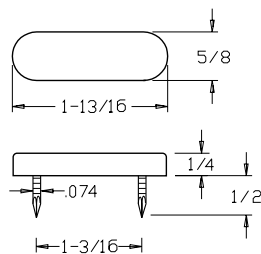
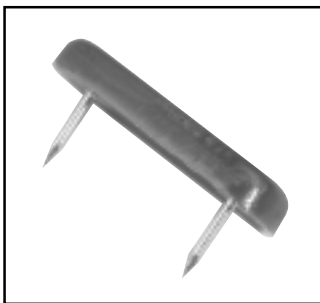

33-2019

The Double-Size, Double-Nail Glide

With its broad 1-13/16" x 5/8" base and 1/2" nails, this new glide gives your furniture extra stability, a really solid stance. Two nails embedded in the polyethylene base keep the glide in place for good on furniture that needs larger glide surfaces. Available in walnut, 2M pcs per box-weight 21 lbs.

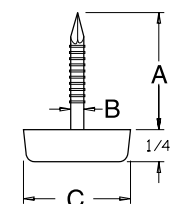

33-6200 **33-6450**

The "Hold-In-Almost-Anything" Glide

Nail this glide into soft woods, wood composites, even the end grain of plywood. The nail's threads and extra length give it more "bite" and a strong grip in softer structural materials. The base is a durable plastic.

PART	COLOR	A	B	C	Pcs/Box	Wt(LBS)
33-2620	Black	7/8	.095	3/4	5M	26
33-6450	Beige	5/8	.073	5/8	5M	15

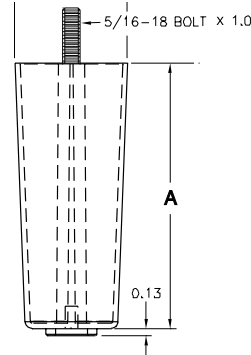
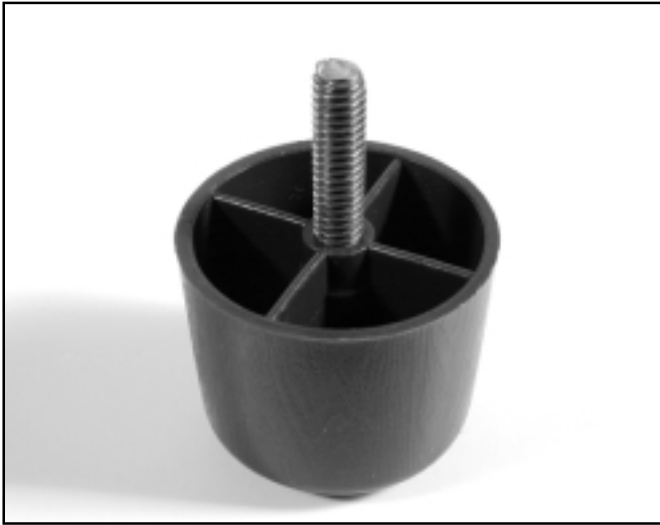

LEGS

Handy's durable plastic assembled with a strong 5/16-18 x 1" bolt will meet your most demanding needs. Inquire about custom packaging.

Plastic Leg w/bolt

PART	A (HIGH)	Pcs/Box	Wt(LBS)
249-SERIES	1-1/2" (PLEASE INQUIRE)		
	2-1/4" (PLEASE INQUIRE)		
	2-1/2" (PLEASE INQUIRE)		
	3" (PLEASE INQUIRE)		
	4"	200	
	5" (PLEASE INQUIRE)		

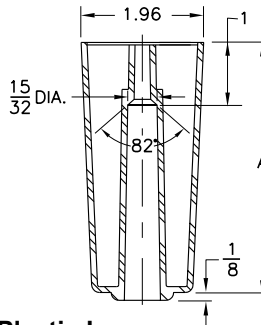

LEGS

Handy's Round and Tri-Legs are extra durable and easily attached. The same length #12 screw can be used to attach any of the leg lengths that Handy offers.

Plastic Leg

PART	A (HIGH)	Pcs/Box	Wt(LBS)
249-SERIES	1-1/2" (PLEASE INQUIRE)		
	2-1/2" (PLEASE INQUIRE)		
	3" (PLEASE INQUIRE)		
	4"	200	24

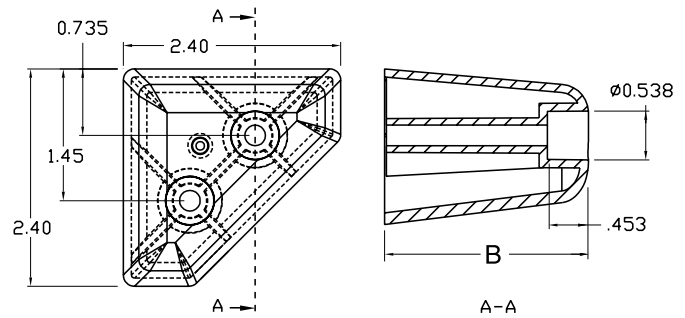

Plastic Tri-Leg

PART	B (HIGH)	Pcs/Box	Wt(LBS)
249-1000	1-1/4	500	
249-1002	1-3/4	400	
249-1001	2-1/4	250	19

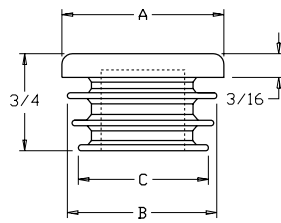

Tube Closures

TUBE CLOSURES

Handy Tube Closures have a unique “finned” design that keeps them tight in both 16 and 18 gauge tubing. You don’t have to stock two sizes of closures. The black, polyethylene closures are strong enough to be used as glides, as well. Inquire for color.

PART	FIT HOLE	A	B	C	Pcs/Box	Wt(LBS)
35-416	1	1.031	.934	.868	1M	10
35-417	1-1/8	1.156	1.059	.992	1M	13
35-418	1-1/4	1.281	1.184	1.118	1M	15

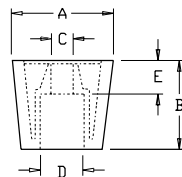

29-Series

CASE FEET

Our molded Case Feet are available in a variety of sizes for a wide range of applications. They can easily be attached to wood, metal or plastic with screws and other fasteners. Their multi-ribbed design offers exceptional strength to take heavy loads without deforming. They may also be used as floor glides and bumpers for hinged or sliding doors. Available in brown or black. Made of polyethylene.

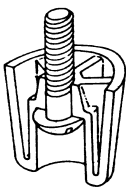

PART	A	B	C	D	E	Pcs/Box	Wt(LBS)
29-140	7/8	1/2	13/64	3/8	1/4	10M	49
29-141	7/8	5/8	13/64	3/8	1/4	8.5M	41
29-142	1	3/4	13/64	3/8	3/8	5M	44
29-143	1-1/8	7/8	1/4	15/32	3/8	3.5M	35
29-144	1-1/8	1	1/4	1/2	3/8	3.25M	49
29-145	7/8	1/2	1/4	3/8	1/4	10M	48
29-275	7/8	3/8	5/32	5/16	3/16	10M	41

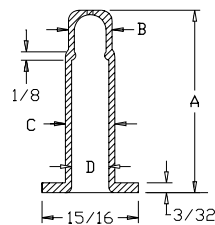
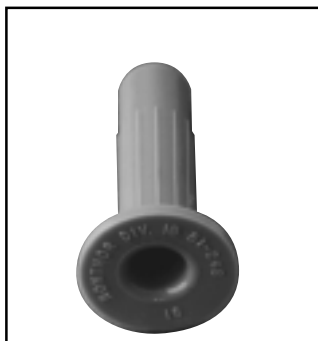

Castor Sockets

CASTER SOCKETS

These self-lubricating Plastic Caster Sockets are a major improvement over metal types. They absorb caster noise and won’t squeak. They work equally well with ball-bearing stem or plain-stem casters. Sockets are vented to prevent collapse when driven into blind holes. Their ridged stems hold them securely in place. Available in beige. Made of polyethylene.

PART	A	B	C	D (CASTER STEM)	HOLE SIZE Req'd	Pcs/Box	Wt(LBS)
51-248	1-11/16	.430	.460	5/16 Dia.	7/16 Dia. x 1-7/8 Deep	5M	30
51-259	1-47/64	.488	.515	3/8 Dia.	1/2 Dia. x 1-7/8 Deep	4M	28

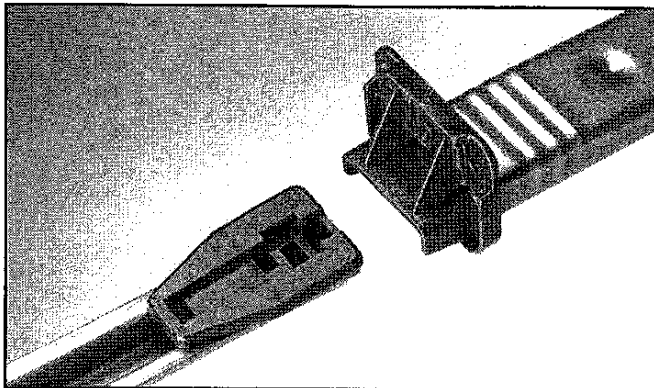

RITE-TRAK® - Residential Model

The Rite-Trak drawer guide system has been the specified choice of leading manufacturers for many years. The self lubricating plastic components provide the smooth quiet ride that can't be found in any other system. Steel guides and runners are built to your specifications, with options and features that make installation quick and easy.

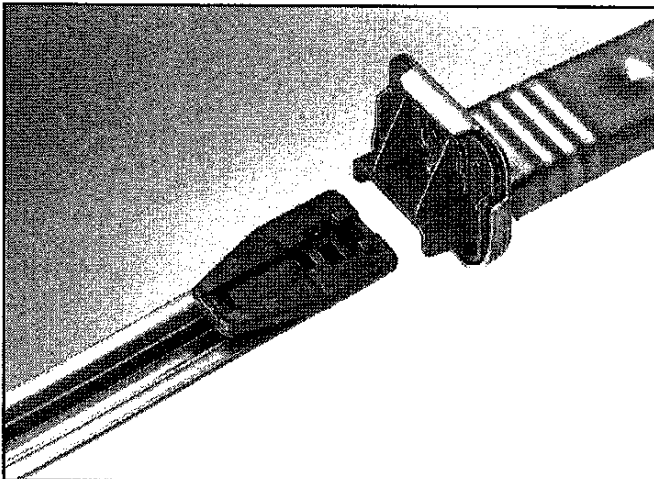
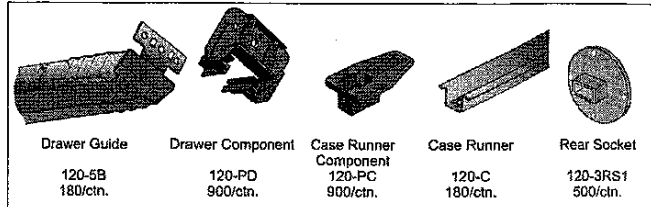

RITE-TRAK® - Contract Model

The Rite-Trak drawer guide system has been the specified choice of leading manufacturers for many years. A heavy-duty version meets the demands of rugged commercial/institutional use.

Added steel reinforcement at all stress points on the drawer component and case runner give greater load capacity to withstand a lifetime of hotel/motel use.

Load Rating: 120 lbs.

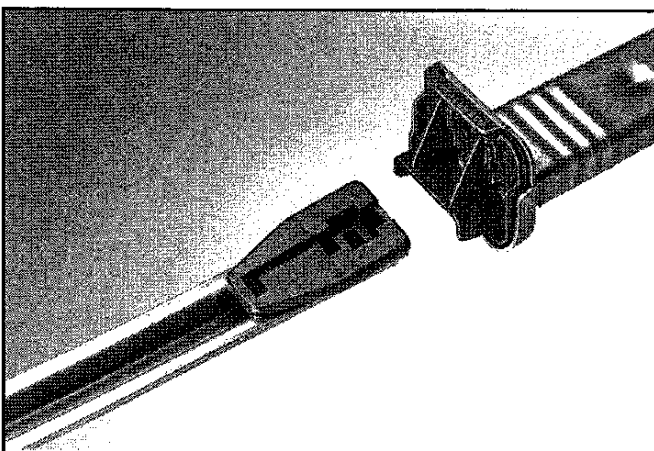
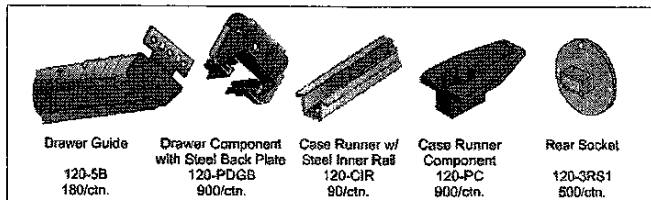

RITE-TRAK® - Youth Group Model

The Rite-Trak drawer guide system has been the specified choice of leading manufacturers for many years. Kenlin's steel reinforced back plate can handle the increased drawer size and added load capacity of youth group furniture. The self lubricating plastic components provide the smooth quiet ride that can't be found in any other system. Steel guides and runners are built to your specifications, with options and features that make installation quick and easy.

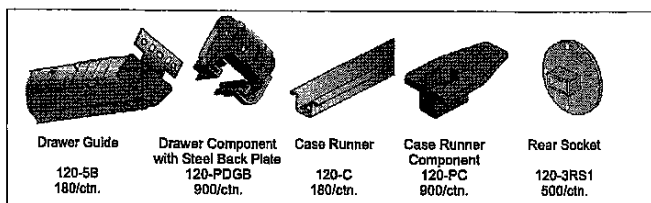

Measuring drawer guides

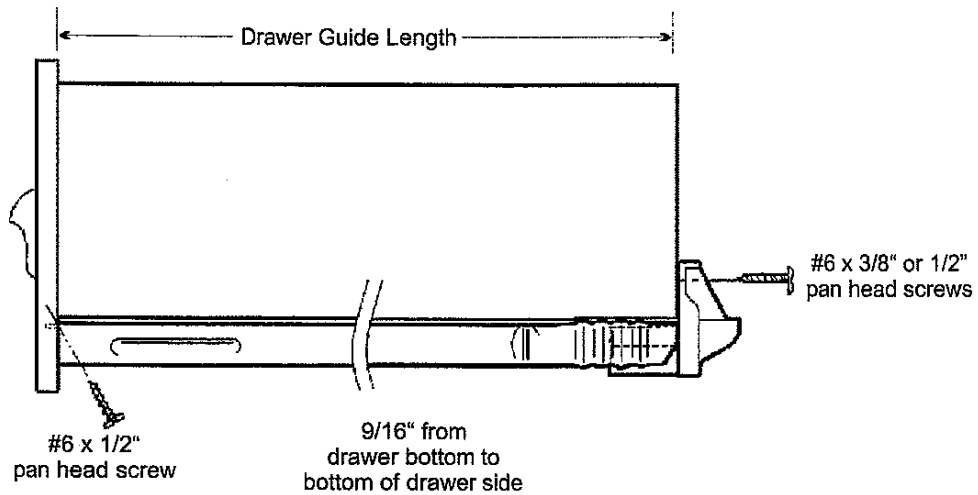

Drawer Guide - Indicate length from back of drawer front to back of drawer back in 1/4" increments up to 18-3/4" length.

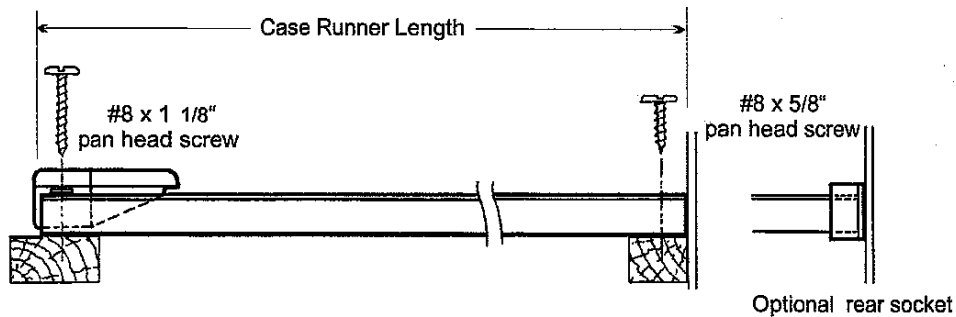

Case Runner - Indicate length from front rail to back of back rail in 1/4" increments up to 28 max.

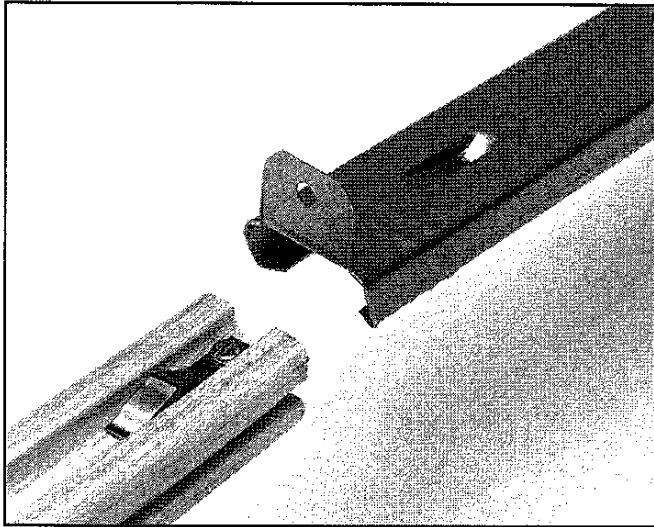

Glide Rite #180 - Drawer Guides

The proven dependable guiding system used by leading case good producers. The drawer guide system has a stop feature utilizing a shear form detent in the drawer guide and a spring clip that fits into a groove in the wood case runner. Each guide is custom made to fit drawers with sides measuring 8"-18 1/2" long and offers Kenlin's exclusive Aero-Ribbed design for added strength and reinforcement. A number of options are available to assure fast, easy installation with staples or screws. Kenlin will custom engineer this system to meet specific individual plant requirements.

PART #	DESCRIPTION	PACKAGING
180 Drawer Guide	Cold rolled precision formed steel	180-225 pcs/carton
180-SCF	Spring clip	5,000 pcs/carton

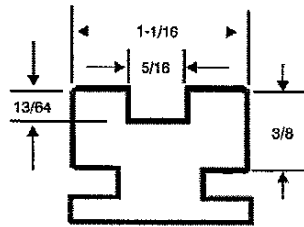

Wood Case Runner Dimensions*
*(Wood Case Runner Not Included)

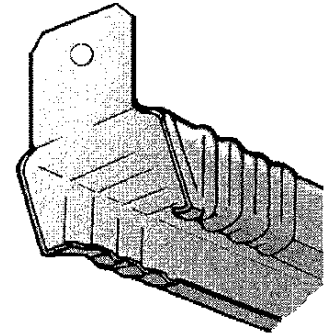

Patented Aero-Ribbed Design

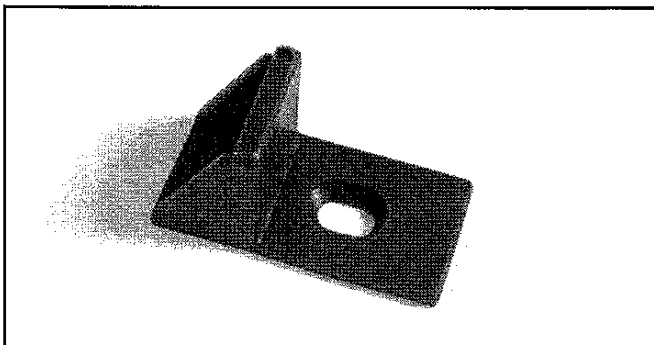

Case Glides

PART #	GLIDE THICKNESS	CASE PACKAGING
75-2.1CG	2.1 mm (.080")	5000 pcs/ctn
75-3.1CG	3.1 mm (.120")	5000 pcs/ctn



847-459-0900
ReadytoWow@handykenlin.com

handykenlin.com

29 E. Hintz Road
Wheeling, IL 60090